



Compact & Conventional Series (CE) Operating Manual

This manual must be kept and stored with the aerial platform at all times.

**Models 3215, 3219, 3220, 3226
4620, 4626, 4632, 6826 & 6832**

Skyjack Head Office 55 Campbell Rd. Guelph, Ontario N1H 1B9

Phone: 519-837-0888

Toll Free: 1-800-265-2738

Fax: 519-837-8104

Email: skyjack@skyjack.com

www.skyjack.com

Part No. 143881AC-A

USE THE SERIAL NUMBER OF YOUR MACHINE TO DETERMINE THE CORRECT OPERATING MANUAL TO USE							
Manual Part #	I18942AD	I22882AJ	I22908AE	I29908AE	I29917AF	I43856AC	I43881AC
Release Date	July 2003	July 2003	July 2003	July 2003	April 2006	February 2008	November 2008
M	3015	150931 & Below	150932 to 151981	Not Used		Not Used	Not Used
	3219	229632 & Below	229633 to 236285	Not Used		Not Used	Not Used
O	3215	Not Used		151982 to 152099	152100 to 152169	152170 to 154002	10 000 001 to 10 000 329
	3219	Not Used		236286 to 237573	237574 to 239691	239692 to 268399	22 000 001 to 22 013 837
D	3220	611286 & Below	611287 to 613550	613551 to 615016	615017 to 615505	615506 to 620094	60 000 001 to 60 001 522
	3226	Not Used	27013 to 28042	28043 to 28047	270931 to 271776	271777 to 279956	27 000 001 to 27 004 499
E	4620	66658 & Below	66659 to 66875	Not Used		66876 to 66889	70 000 001 to 70 004 719
	4626	706174 & Below	706175 to 709362	Not Used		709363 to 709588	
L	4632	Not Used		Not Used		Not Used	70 004 720 & Above
	4830/32	87564 & Below	87565 to 870780	Not Used		870781 to 871159	
	6826	75578 & Below	75579 to 75618	Not Used		75619	
	6832	82573 & Below	82574 to 83066	Not Used		83067 to 83100	
					83101 to 83311	80 000 001 to 80 000 112	80 000 113 & Above

60312AS-CE-R

Skyjack Service Center 3451 Swenson Ave. St. Charles, Illinois, 60174 USA

Phone: 630-262-0005

Toll Free: 1-800-275-9522

Fax: 630-262-0006

Email: service@skyjack.com

Parts (North America)

Toll Free: 1-800-965-4626

Toll Free Fax: 1-888-782-4825

Email: parts@skyjack.com

Parts & Service (Europe) Glovers Meadow, Maesbury Rd. Oswestry, Shropshire, SY10 8NH UK

Phone: +44-1691-676-235

Fax: +44-1691-676-238

Email: info@skyjackeurope.co.uk

Skyjack Asia Pacific

Singapore

Phone: +65-6449-3710

Fax: +65-6449-7690

Email: skyjack@singnet.com.sg

The Safety Alert Symbol identifies important safety messages on aerial platform, safety signs in manuals or elsewhere. When you see this symbol, be alert to the possibility of personal injury or death. Follow the instructions in the safety message.



This Safety Alert Symbol means attention!

Become alert! Your safety is involved.



DANGER

DANGER indicates an imminently hazardous situation which, if not avoided, will result in death or serious injury.



WARNING

WARNING indicates a potentially hazardous situation which, if not avoided, could result in death or serious injury.



CAUTION

CAUTION indicates a potentially hazardous situation which, if not avoided, may result in minor or moderate injury. It may also be used to alert against unsafe practices.

IMPORTANT

IMPORTANT indicates a procedure essential for safe operation and which, if not followed, may result in a malfunction or damage to the aerial platform.

Table of Contents

Section 1 - About Your Aerial Platform

Read and Heed

Aerial Platform Definition	7
Purpose of Equipment	7
Use of Equipment	7
Manual.....	7
Operator	7
Service Policy and Warranty	7
Optional Accessories	7
Scope of this Manual	7

Safety Rules

Operator Safety Reminders	8
Electrocution Hazard	8
Safety Precautions	9

Section 2 - Operation

2.1	General	13
2.1-1	Operator Qualifications	13
2.1-2	Operator's Responsibility for Maintenance	13
2.1-3	Maintenance and Inspection Schedule	13
2.1-4	Owner's Inspections	13
2.2	Major Components	14
2.3	Major Assemblies	15
2.3-1	Base	15
2.3-2	Lifting Mechanism	15
2.3-3	Platform	15
2.4	Serial Number Nameplate	15
2.5	Component Identification	16
2.5-1	Main Power Disconnect Switch	16
2.5-2	Tilt Alarm	16
2.5-3	Load Sensing System	16
2.5-4	Base Control Console	17
2.5-5	Electrical Panel.....	17
2.5-6	Brake System	17
2.5-7	Free-wheeling Valve	18
2.5-8	Battery Charger	18
2.5-9	Pothole Protection Device.....	18
2.5-10	Emergency Lowering System.....	19
2.5-11	Lowering Warning System.....	19
2.5-12	Maintenance Support	19
2.5-13	Platform Control Console	20
2.5-14	Manual Storage Box	20
2.5-15	Folding Guardrail System	20
2.5-16	Lanyard Attachment Anchorage.....	21

Table of Contents

Section 2 - Operation (Continued)

2.6	Component Identification (Special Options).....	22
2.6-1	Powered Extension Control Console (If Equipped)	22
2.6-2	1500W AC Inverter (If Equipped)	22
2.6-3	Motion Alarm (If Equipped).....	22
2.7	Operator' Responsibility	23
2.8	Visual and Daily Maintenance Inspections	24
2.9	Function Tests.....	31
2.10	Start Operation	38
2.10-1	To Activate Base Control Console	38
2.10-2	To Raise or Lower Platform Using Base Control Console.....	38
2.10-3	To Activate Platform Control Console.....	39
2.10-4	To Raise or Lower Platform Using Platform Control Console	39
2.10-5	To Drive Forward or Backward	40
2.10-6	To Steer	40
2.10-7	To Select Level Drive or Inclined Drive Mode	41
2.10-8	To Extend/Retract Manual Extension Platform	41
2.10-9	To Extend/Retract Powered Extension Platform (If Equipped).....	42
2.10-10	Electrical Inverter (If Equipped)	42
2.10-11	Shutdown Procedure	42
2.11	Guardrail Folding Procedure.....	43
2.12	Loading/Unloading.....	44
2.12-1	Lifting.....	44
2.12-2	Driving	45
2.13	Moving the Aerial Platform Through a Doorway.....	46
2.14	Winching and Towing Procedures	48
2.14-1	To Release Free-wheeling Valve	48
2.14-2	To Release Brakes Manually.....	49
2.14-2a	Pin Brakes System.....	49
2.14-2b	Disc Brakes System.....	49
2.15	Emergency Lowering Procedure	50
2.16	Maintenance Support Procedure.....	51
2.17	Battery Maintenance	52
2.17-1	Battery Service Procedures	52
2.17-2	Battery Charging Operation.....	52
2.18	Tables.....	56
2.19	Labels	66

List of Tables

Table 2.1	Standard and Optional Features	56
Table 2.2	Owner's Annual Inspection Record	57
Table 2.3	Specifications and Features.....	58
Table 2.4	Floor Loading Pressure.....	60
Table 2.5	Maximum Platform Capacities (Evenly Distributed)	62
Table 2.6	EC Declaration of Conformity	63
Table 2.7	Maintenance and Inspection Schedule	64
Table 2.8	Operator's Checklist	65

SKYJACK is continuously improving and expanding product features on its equipment, therefore, specifications and dimensions are subject to change without notice.

Aerial Platform and Mobile Elevating Work Platform Definition

A mobile device that has a positionable platform supported from ground level by a structure.

Purpose of Equipment

The SKYJACK SJIII Compact and Conventional series aerial platforms are designed to transport and raise personnel, tools and materials to overhead work areas.

Use of Equipment

The aerial platform is a highly maneuverable, mobile work station. Lifting and driving must be on a flat, level, compacted surface.

Manual

The operating manual is considered a fundamental part of the aerial platform. It is a very important way to communicate necessary safety information to users and operators. A complete and legible copy of this manual must be kept in the provided weather-resistant storage compartment on the aerial platform at all times.

Operator

The operator must read and completely understand both this operating manual and the safety panel label located on the platform and all other warnings in this manual and on the aerial platform. Compare the labels on the aerial platform with the labels found within this manual. If any labels are damaged or missing, replace them immediately.

Service Policy and Warranty

SKYJACK warrants each new SJIII Series work platform to be free of defective parts and workmanship for the first 24 months. Any defective part will be replaced or repaired by your local SKYJACK dealer at no charge for parts or labor. Contact the SKYJACK Service Department for warranty statement extensions or exclusions.

Optional Accessories

The SKYJACK aerial platform is designed to accept a variety of optional accessories. These are listed under “Standard and Optional Features” in Table 2.1.

Operating instructions for these options **(if equipped)** are located in Section 2 of this manual.

For options not listed under “Standard and Optional Features,” contact the SKYJACK Service Department at

 : 44-1691-676-235

 : 44-1691-676-239

Include the model and serial number for each applicable aerial platform.

Scope of this Manual

- a. This manual applies to the CE version of the SJIII Series aerial platform models listed on Table 2.1.

Equipment identified with “CE” meets the requirements for the European countries, i.e., Machinery Directive 98/37/EC and Directive 89/336/EEC and the corresponding EN standards.

- b. Operators are required to conform to national, state or territorial/provincial and local health and safety regulations applicable to the operation of this aerial platform.



WARNING

Failure to comply with your required responsibilities in the use and operation of the aerial platform could result in death or serious injury!

Operator Safety Reminders

A study conducted by St. Paul Travelers showed that most accidents are caused by the failure of the operator to follow simple and fundamental safety rules and precautions.

You, as a careful operator, are the best insurance against an accident. Therefore, proper usage of this aerial platform is mandatory. The following pages of this manual should be read and understood completely before operating the aerial platform.

Common sense dictates the use of protective clothing when working on or near machinery. Use appropriate safety devices to protect your eyes, ears, hands, feet and body.

Any modifications from the original design are strictly forbidden without written permission from SKYJACK.

Electrocution Hazard

This aerial platform is not electrically insulated. Maintain a Minimum Safe Approach Distance (MSAD) from energized power lines and parts as listed below. The operator **must allow** for the platform to sway, rock or sag. **This aerial platform does not provide protection from contact with or proximity to an electrically charged conductor.**

**DO NOT USE THE AERIAL PLATFORM AS A GROUND FOR WELDING.
DO NOT OPERATE THE AERIAL PLATFORM DURING LIGHTNING OR STORMS.**

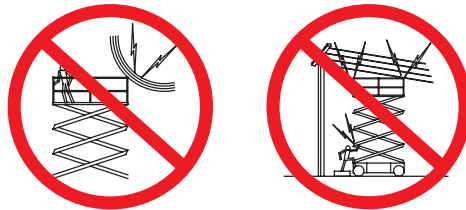

DANGER

Avoid Power Lines

Minimum Safe Approach Distance

CE Guidance Note

“Avoidance of danger from overhead lines”

Adhere strictly to the governmental rulings and regulations applicable in your country.

FAILURE TO AVOID THIS HAZARD WILL RESULT IN DEATH OR SERIOUS INJURY!

60023AE-CE

Safety Precautions

Know and understand the safety precautions before going on to next section.



WARNING

Failure to heed the following safety precautions could result in tip over, falling, crushing, or other hazards leading to death or serious injury.

- **KNOW** all national, state or territorial/provincial and local rules which apply to your aerial platform and jobsite.
- **TURN** main power disconnect switch “O” off when leaving the aerial platform unattended. Remove the key to prevent unauthorized use of the aerial platform.
- **WEAR** all the protective clothing and personal safety devices issued to you or called for by job conditions.

- **DO NOT** wear loose clothing, dangling neckties, scarves, rings, wristwatches or other jewelry while operating this lift.

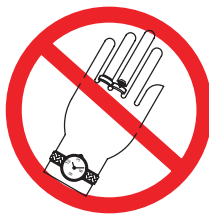

- **AVOID** entanglement with ropes, cords or hoses.



- **AVOID** falling. Stay within the boundaries of the guardrails.

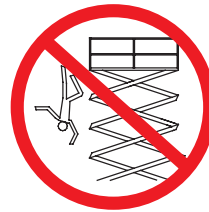

- **DO NOT** raise the aerial platform in windy or gusty conditions.



- **DO NOT** increase the lateral surface area of the platform. Increasing the area exposed to the wind will decrease aerial platform stability.



- **DO NOT** drive or elevate the aerial platform if it is not on a firm level surface. Do not drive elevated near depressions or holes of any type, loading docks, debris, drop-offs and surfaces that may affect the stability of the aerial platform.



- **If operation in areas with holes or drop-offs is absolutely necessary**, elevated driving shall not be allowed. Position the aerial platform horizontally only with the platform fully lowered. After ensuring that all 4 wheels or outriggers (if equipped) have contact with level firm surface, the aerial platform can be elevated. After elevation, the drive function must not be activated.



- **Elevated driving** must only be done on a firm level surface.



- **DO NOT** ascend or descend a grade when elevated. When fully lowered, ascending or descending, only grades up to rated maximum listed in Table 2-3a and Table 2-3b are permissible.



Safety Precautions (Continued)

Know and understand the safety precautions before going on to next section.

- **DO NOT** operate on surfaces not capable of holding the weight of the aerial platform including the rated load, e.g. covers, drains, and trenches.

- **DO NOT** operate an aerial platform that has ladders, scaffolding or other devices mounted on it to increase its size or work height. It is prohibited.



- **DO NOT** exert side forces on aerial platform while elevated.



- **DO NOT** use the aerial platform as a crane. It is prohibited.



- **DO NOT** sit, stand or climb on the guardrails. It is prohibited.



- **DO NOT** climb on scissor arm assembly. It is prohibited.



- **BE AWARE** of overhead obstructions or other possible hazards around the aerial platform when driving or lifting.



- **DO NOT** raise the aerial platform while the aerial platform is on a truck, fork lift or other device or vehicle.



- **BE AWARE** of crushing hazards. Keep all body parts inside platform guardrail.



- **DO NOT** lower the platform unless the area below is clear of personnel and obstructions.



- **ENSURE** that there are no personnel or obstructions in the path of travel, including blind spots.



- **BE AWARE** of blind spots when operating the aerial platform.

- **STUNT** driving and horseplay are prohibited.

- **ENSURE ALL** tires are in good condition and lug nuts are properly tightened.

- **DO NOT** alter or disable limit switches or other safety devices.

- **DO NOT** use the aerial platform without guardrails, locking pins and the entry gate in place.

Safety Precautions (Continued)

Know and understand the safety precautions before going on to next section.

- **DO NOT** exceed the rated capacity of the aerial platform. Do make sure the load is evenly distributed on the platform.
- **DO NOT** attempt to free a snagged platform with lower controls until personnel are removed from the platform.
- **DO NOT** position the aerial platform against another object to steady the platform.
- **DO NOT** place materials on the guardrails or materials that exceed the confines of the guardrails unless approved by Skyjack.



WARNING

Entering and exiting the aerial platform should only be done using the three points of contact.

- Use only equipped access openings.
- Enter and exit only when the aerial platform is in the fully retracted position.
- Do use three points of contact to enter and exit the platform. Enter and exit the platform from the ground only. Face the aerial platform when entering or exiting the platform.
- Three points of contact means that two hands and one foot or one hand and two feet are in contact with the aerial platform or the ground at all times during entering and exiting.



WARNING

An operator should not use any aerial platform that:

- does not appear to be working properly.
- has been damaged or appears to have worn or missing parts.
- has alterations or modifications not approved by the manufacturer.
- has safety devices which have been altered or disabled.
- has been tagged or locked out for non-use or repair.

Failure to avoid these hazards could result in death or serious injury.

Jobsite Inspection

- Do not use in hazardous locations.
- Perform a thorough jobsite inspection prior to operating the aerial platform, to identify potential hazards in your work area.
- Be aware of moving equipment in the area. Take appropriate actions to avoid collision.

2.0 Operation

This section provides the necessary information needed to operate the aerial platform. It is important that the user reads and understands this section before operating the aerial platform.

2.1 General

In order for this aerial platform to be in good working condition, it is important that the operator meets the necessary qualifications and follow the maintenance and inspection schedule referred to in this section.

2.1-1 Operator Qualifications

- Only trained and authorized personnel shall be permitted to operate an aerial platform.
- Safe use of this aerial platform requires the operator to understand the limitations and warnings, operating procedures and operator's responsibility for maintenance. Accordingly, the operator must understand and be familiar with this operating manual, its warnings and instructions, and all warnings and instructions on the aerial platform.
- The operator must be familiar with employer's work rules and related government regulations and be able to demonstrate the ability to understand and operate this make and model of aerial platform in the presence of a qualified person.

2.1-2 Operator's Responsibility for Maintenance



WARNING

Maintenance must be performed by trained and competent personnel who are familiar with mechanical procedures.

Death or serious injury could result from the use of an aerial platform that is not properly maintained or kept in good working condition.

- The operator must be sure that the aerial platform has been properly maintained and inspected before using it.
- The operator must perform all the daily inspections and function tests found in Table 2.7, even if the operator is not directly responsible for the maintenance of this aerial platform.

2.1-3 Maintenance and Inspection Schedule

- The inspection points covered in Table 2.7 indicate the areas of the aerial platform to be maintained or inspected and at what intervals the maintenance and inspections are to be performed.
- The actual operating environment of the aerial platform may affect the maintenance schedule.



WARNING

Use original or manufacturer-approved parts and components for the aerial platform.

2.1-4 Owner's Inspections

It is the responsibility of the owner to arrange daily, quarterly (or 150 hours) and annual inspections of the aerial platform. Refer to Table 2.7 for recommended maintenance and inspection areas and intervals. A record of annual inspection is kept on a label located on the scissor assembly. Refer to Table 2.2 in this manual.

2.2 Major Components

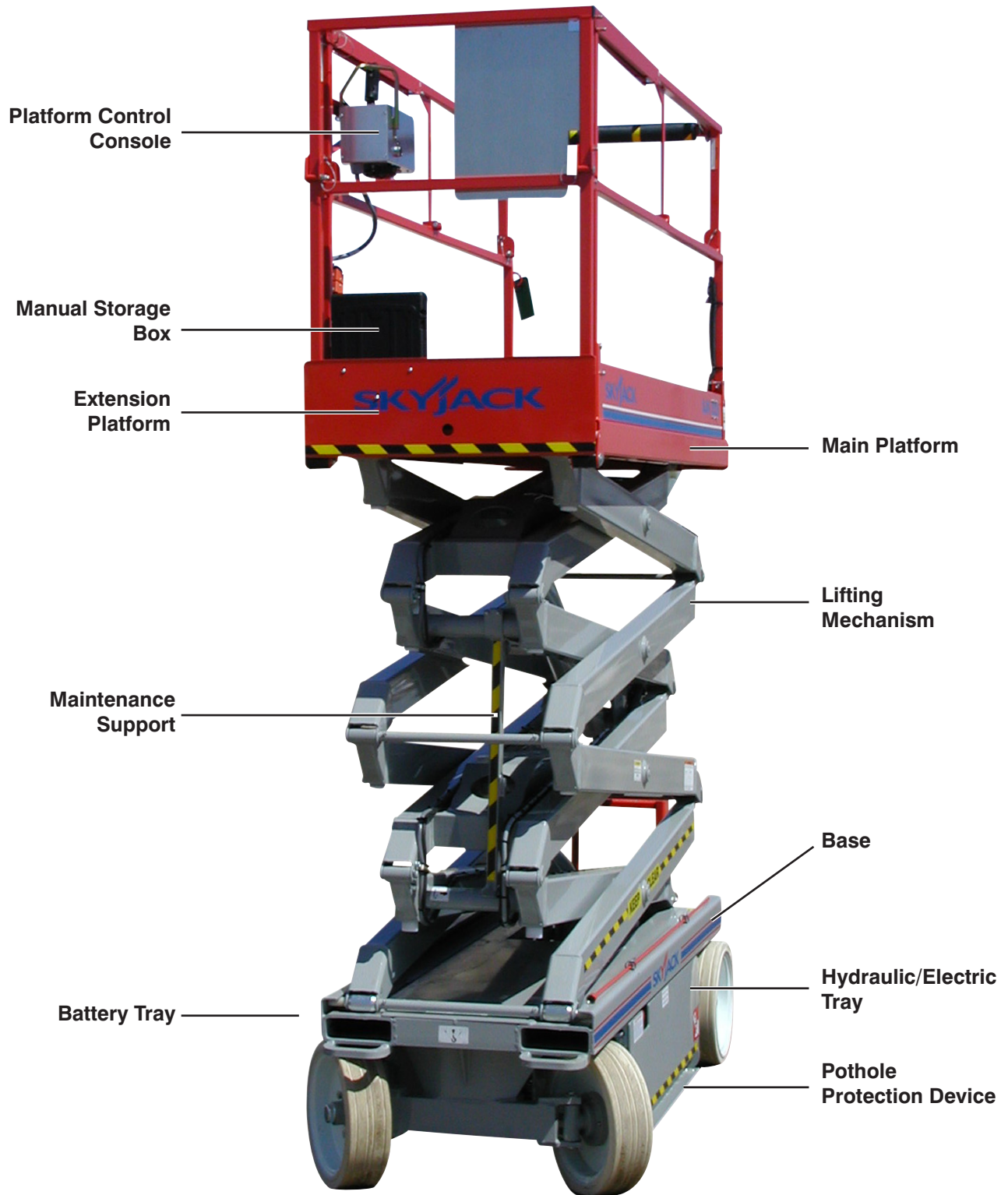

SKYJACK SJIII Series Aerial Platform

2.3 Major Assemblies

The aerial platform consists of three major assemblies: base, lifting mechanism and platform.

2.3-1 Base

The base is a rigid, one-piece weldment which supports two swing out trays.

Pothole Protection:

Located under the outer edge of each tray, a mechanically actuated angle rotates when platform is elevated. This mechanism provides pothole protection for elevated driving (except models 6826 and 6832).

On Models 3215 and 3219 (Compacts):

One tray contains the hydraulic and electrical components. The other tray contains four (4) 6 volt batteries. The charger is located at the rear of the aerial platform. The front axle has two hydraulic motor-driven wheels, steerable by a hydraulic cylinder. The rear axle is fixed and has non-driven, spring-applied, hydraulically released brake.

On Models 3220, 3226, 4620, 4626, 4632, 6826 and 6832 (Conventionals):

One tray contains the hydraulic and electrical components. The other tray contains battery charger and four (4) 6 volt batteries. The front axle has two non-driven wheels, steerable by a hydraulic cylinder. The rear axle has two hydraulic motor-driven wheels with spring-applied, hydraulically released brakes.

2.3-2 Lifting Mechanism

The lifting mechanism is constructed of formed steel or tube sections making up a scissor-type assembly. The scissor assembly is raised and lowered by single-acting hydraulic lift cylinders with holding valves. A pump, driven by an electric motor, provides hydraulic power to the lift cylinders.

2.3-3 Platform

The platform is constructed of a tubular support frame, a skid-resistant "diamond plate" deck surface and 1.1 m hinged guardrails with 0.15 m toe boards and mid-rails. The platform can be entered from the rear through a spring-returned gate with latch. The platform is also equipped with a manual extension platform. An AC outlet is also located on the platform.

2.4 Serial Number Nameplate

The serial number nameplate, located at the rear of the aerial platform, lists the following:

- Model number
- Serial number
- Aerial platform weight
- Maximum drivable height
- Maximum capacities
- Maximum number of persons permissible on the platform
- Voltage
- System pressure
- Lift pressure
- Maximum platform height
- Maximum wheel load
- Maximum wind speed
- Maximum manual force
- Maximum incline

2.5 Component Identification

The following descriptions are for identification, explanation and locating purposes only.

2.5-1 Main Power Disconnect Switch

This switch is located at the rear of the base.

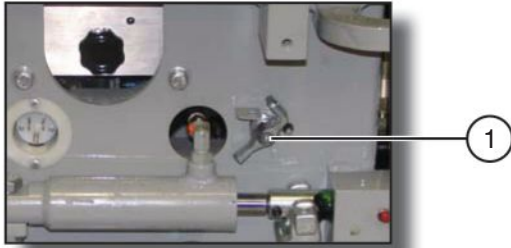

Figure 2-1. Main Power Disconnect Switch

1. **Main Power Disconnect Switch** - This switch, when in “○” off position, disconnects power to all circuits. Switch must be in “I” on position to operate any circuit. Turn switch “○” off when transporting aerial platform.

2.5-2 Tilt Alarm

The aerial platform is equipped with a device which senses when the aerial platform is out of level in any direction. When activated, it disables drive and lift functions of the aerial platform and an alarm produces an audible sound accompanied by the amber light (if equipped).



WARNING

If the tilt alarm sounds and the platform does not, or only partially raises, immediately lower the platform completely and ensure that the aerial platform is on a firm level surface.

2.5-3 Load Sensing System

This system is a safety device that will prevent any normal movement of the aerial platform from a stationary working position after the rated load is reached and exceeded. Refer to Table 2.5 for maximum platform capacities.

- **When 90% of the rated load is reached:**
The red power indicator light on the platform control console flashes.
- **When the rated load is reached:**
An audible alarm sounds for approximately 2 seconds, 5 times per minute.
- **When the rated load is exceeded:**
The flashing light and audible alarm continue and all electrically controlled aerial platform movement functions stop. To resume normal operation, remove the overload from the platform.
- **If the aerial platform comes in contact with an overhead obstruction:**
The platform could become overloaded and all functions would stop. Release of the platform from this situation can only be effected by use of the emergency lowering system. Refer to Section 2.15.

NOTE

After reaching full extension and upon lowering, the aerial platform could stop and take an overload reading. Return the controller to the neutral center position, and release the enable trigger switch. If the aerial platform is overloaded, the flashing light and audible alarm continue and all electrically controlled aerial platform movement functions stop. To resume normal operation, remove the overload from the platform.

2.5-4 Base Control Console

This control console is located at the rear of the base. It contains the following controls:

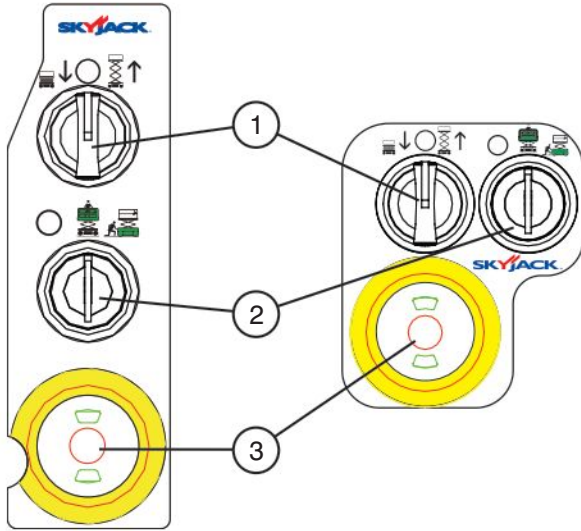

Figure 2-2. Base Control Console

1. **Lower/Neutral/Raise Switch** - This switch controls “ ” raising or “ ” lowering of platform.
2. **Off/Platform/Base Key Switch** - This three-way switch allows the operator to turn “ ” off power to aerial platform or to activate either “ ” platform or “ ” base controls.
3. **Emergency Stop Button** - This button “ ”, when depressed, disconnects power to the control circuit.

2.5-5 Electrical Panel

This panel is located in the hydraulic/electric tray. It contains the following controls:

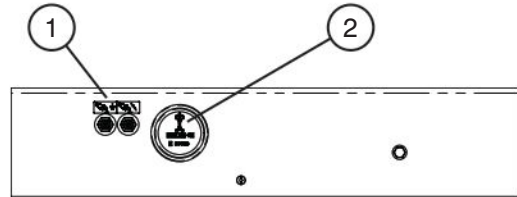

Figure 2-3. Electrical Panel

1. **Circuit Breaker Resets** - In the event of power overload or positive circuit grounding, the circuit breaker pops out. Push the breaker back in to reset.
2. **Hourmeter** - This gauge records accumulated operating time of the aerial platform.

2.5-6 Brake System

The brake system is located at the rear of the base. The brakes must be manually disengaged before pushing, winching or towing. Refer to Section 2.14-2 for procedure on how to release brakes manually. The system contains the following controls:



Pin Brakes (If Equipped)



Disc Brakes (If Equipped)

Figure 2-4. Brake System

1. Brake auto reset valve plunger
2. Brake hand pump

2.5-7 Free-wheeling Valve

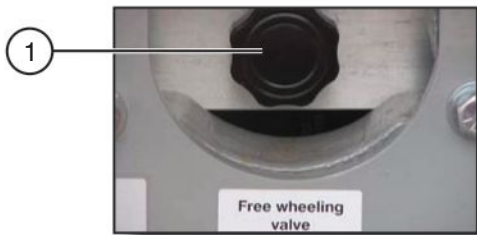

Models 3220, 3226, 46xx and 68xx



Models 3215 and 3219

Figure 2-5. Free-wheeling Valve

1. **Free-wheeling Valve** - The free-wheeling valve is located at the front and/or rear of the aerial platform (depending on the model). Refer to Section 2.14-1 for procedure on how to release the free-wheeling valve.

2.5-8 Battery Charger

The charger is located at the rear of the base or inside the battery tray. Refer to Section 2.17-2 for battery charging operation.

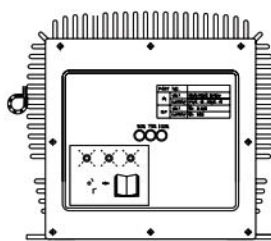

Figure 2-6. Battery Charger

2.5-9 Pothole Protection Device



Figure 2-7. Pothole Protection Device

1. **Pothole Protection Device** - This device consists of a set of mechanically actuated steel weldments located under the hydraulic/electric tray and battery tray. These weldments will automatically rotate for reduced ground clearance when elevating the aerial platform. If the pothole protection device has not fully lowered, the drive function will be disabled.



WARNING

Crushing Hazard - Personnel on ground must stay clear of pothole protection device.



WARNING

Do not drive elevated in areas where electrical cords or debris are in the path of travel.

Maintenance of the Pothole Protection Device

As with all safety devices, periodic inspection and maintenance is required to ensure the proper operation of the pothole protection device. This mechanism is designed to reduce ground clearance and assist in the stability of an elevated aerial platform in the event the aerial platform encounters a “drop-off” or “pothole.” The nature of this safety feature relies on maintaining a consistent ground clearance, therefore, if the aerial platform ever does come to rest on the pothole device, the platform should be immediately lowered and “locked out” to prevent further use until a complete inspection of the mechanism is performed by a qualified technician.

2.5-10 Emergency Lowering System

This emergency lowering system allows platform lowering in the event of an emergency or an electrical system failure. Refer to Section 2.15 for the emergency lowering procedure. The system contains the following controls:

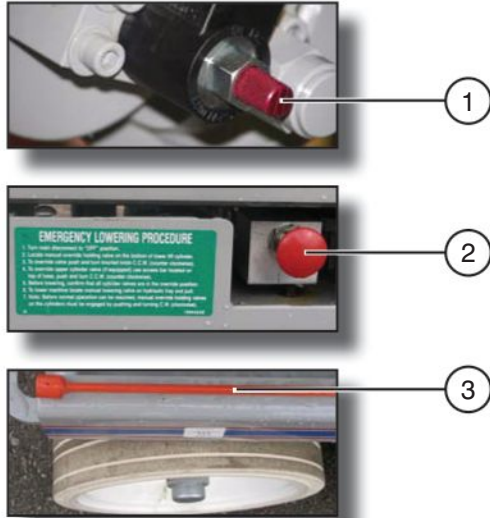

Figure 2-8. Emergency Lowering System

1. **Holding Valve Manual Override Knob** - Located on the holding valve at the bottom of each lift cylinder.
2. **Emergency Lowering Valve** - Located at the rear of the hydraulic/electric tray.
3. **Access Rod** (3226, 4626, 4632 & 68xx) - Located at the left side of the base.

2.5-11 Lowering Warning System

A lowering warning system automatically stops the lowering function before reaching the fully retracted position and sounds an alarm.

2.5-12 Maintenance Support

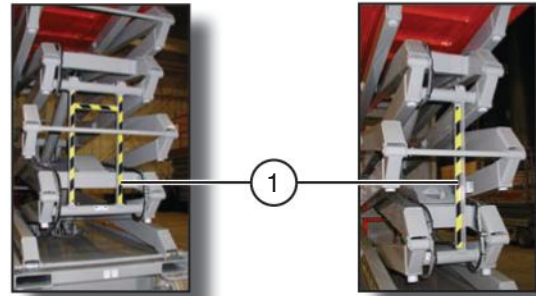

Figure 2-9. Maintenance Support

1. **Maintenance Support** - The maintenance support is a safety mechanism designed to support the scissor assembly. When properly positioned it can support the scissor assembly and empty platform. The maintenance support must be used when inspection and/or maintenance is to be performed within the lifting mechanism. Refer to Section 2.16 for procedure on how use and store the maintenance support.



WARNING

The maintenance support must be used when inspection and/or maintenance or repairs are to be performed within the lifting mechanism. Failure to use this safety mechanism could result in death or serious injury.



WARNING

Do not reach through the scissor assembly when the platform is raised without the maintenance support properly positioned. Failure to avoid this hazard could result in death or serious injury.

2.5-13 Platform Control Console

This removable control console is mounted at the right front of the platform. It contains the following controls:

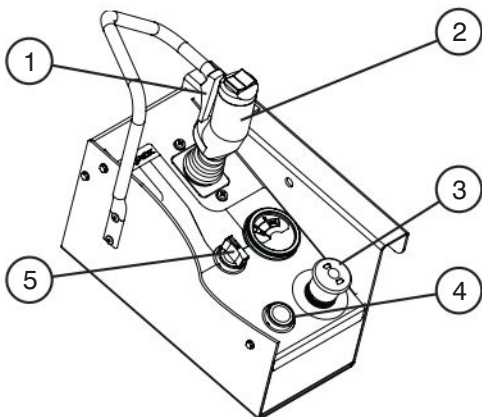

Figure 2-10. Platform Control Console

1. **Lift/Drive/Steer Enable Trigger Switch** - This momentary “” switch energizes the controller. It must be held depressed continuously while engaging either the lift/drive or steer functions.
2. **Lift/Drive/Steer Controller** - This one-hand lever controls lift/drive and steer motions. Internal springs return it to neutral when controller is released.
3. **Emergency Stop Button/Operation Light** - This button “”, when depressed, disconnects power to the control circuit. The operation light indicates upper control availability and overload status. When the light is continuously illuminated, upper controls are available. When the light is flashing, it signals an overload function. Refer to Section 2.5-3.
4. **Horn Pushbutton** - This “” pushbutton sounds an automotive-type horn.
5. **Lift/Inclined Drive/Level Drive Switch** - This switch selects “” lift, “” inclined drive (low speed/high torque) or “” level drive (high speed/low torque).

2.5-14 Manual Storage Box

This weather-resistant box is mounted on the platform railings. It contains the operating manual, EC declaration and other important documents. The operating manual for this make and model of aerial platform must be stored in this box.



2.5-15 Folding Guardrail System

This system, when folded down, reduces the height of the retracted aerial platform for transporting and traveling through doorways only. Refer to Section 2.11 for guardrail folding procedure.

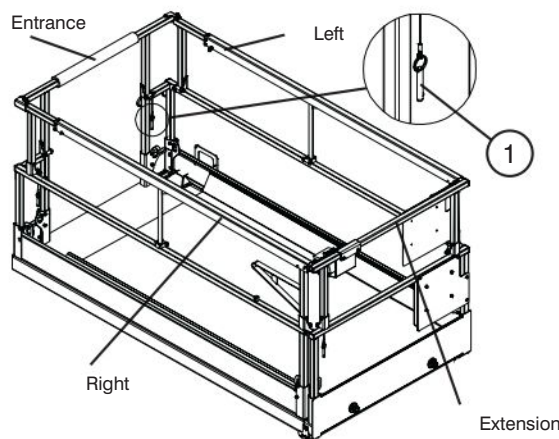

Figure 2-11. Folding Guardrail System

1. **Guardrail Locking Pin with Lanyard** - This pin is used to lock the guardrail in place.



WARNING

The scissor assembly must be fully lowered before raising or lowering the guardrails.

2.5-16 Lanyard Attachment Anchorage

Figure 2-12. Lanyard Attachment Anchorage

1. **Lanyard Attachment Anchorage** - Use this as an attachment point for safety belt/harness tethers. Do not attach belts/harnesses to any other point on the platform. Do not use this point to lift, anchor, secure or support the platform or any other apparatus or material.

**WARNING**

The lanyard attachment anchorage is used for travel restraint, within the limits of the platform only. It is not a fall arresting device! Use as such could result in death or serious injury.

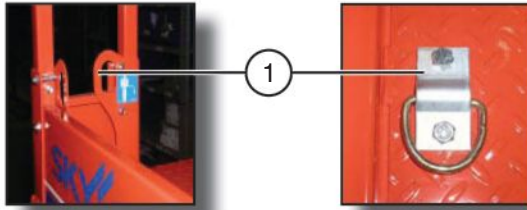
2.6 Component Identification (Special Options)

This section describes the components that are optional to aerial platforms.

2.6-1 Powered Extension Control Console (If Equipped)

This control console is mounted on one of the extension platform guardrails. It contains the following controls:

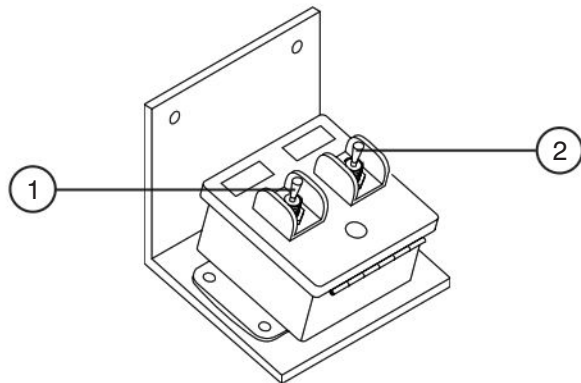
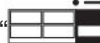



Figure 2-13. Powered Extension Control Console

1. **Enable Switch** - This switch, when activated and held, allows the extension platform extend/retract switch functions to operate.
2. **Extend/Retract Switch** - This switch, when activated, “” extends or “” retracts the powered extension platform. Refer to Section 2.10-9 on how to extend/retract the powered extension platform.

2.6-2 1500W AC Inverter (If Equipped)

The inverter is located on the base of the aerial platform. It has the following controls:



Figure 2-14. 1500W AC Inverter

NOTE

The inverter operation is automatic. These controls do not need to be manipulated for normal operation.

1. **Status LEDs** - These LEDs indicate the operating or fault status of the inverter.
2. **On/Off Switch** - This diagnostic slide switch activates or terminates inverter operation. It should remain in on position.
3. **GFCI Outlet** - During inverter operation, this outlet provides AC power.
4. **15 Amp Circuit Breaker** - In the event of a power overload or circuit grounding, the circuit breaker pops out. Press the breaker back in to reset.

2.6-3 Motion Alarm (If Equipped)

The alarm produces an audible sound when any control function is selected. On aerial platforms with certain options, a flashing amber light will accompany this alarm.

2.7 Operator's Responsibility

It is the responsibility of the operator, prior to each work shift, to perform the following:

1. Visual and Daily Maintenance Inspections

- are designed to discover any damage of components before the aerial platform is put into service.
- are done before the operator performs the function tests.



WARNING

Failure to locate and repair damage, and discover loose or missing parts may result in an unsafe operating condition.

2. Function Tests

- are designed to discover any malfunctions before the aerial platform is put into service.

IMPORTANT

The operator must understand and follow the step-by-step instructions to test all aerial platform functions.

The operator should make a copy of the Operator's Checklist (see Table 2.8) and fill out the visual and daily maintenance inspections and the function tests sections while performing the items outlined in Section 2.8 and Section 2.9.

IMPORTANT

If aerial platform is damaged or any unauthorized variation from factory-delivered condition is discovered, aerial platform must be tagged and removed from service.

Repairs to the aerial platform may only be made by a qualified service technician. After repairs are completed, the operator must perform visual and daily maintenance inspections & function tests again.

Scheduled maintenance inspections shall only be performed by qualified service technician (see Table 2.7).

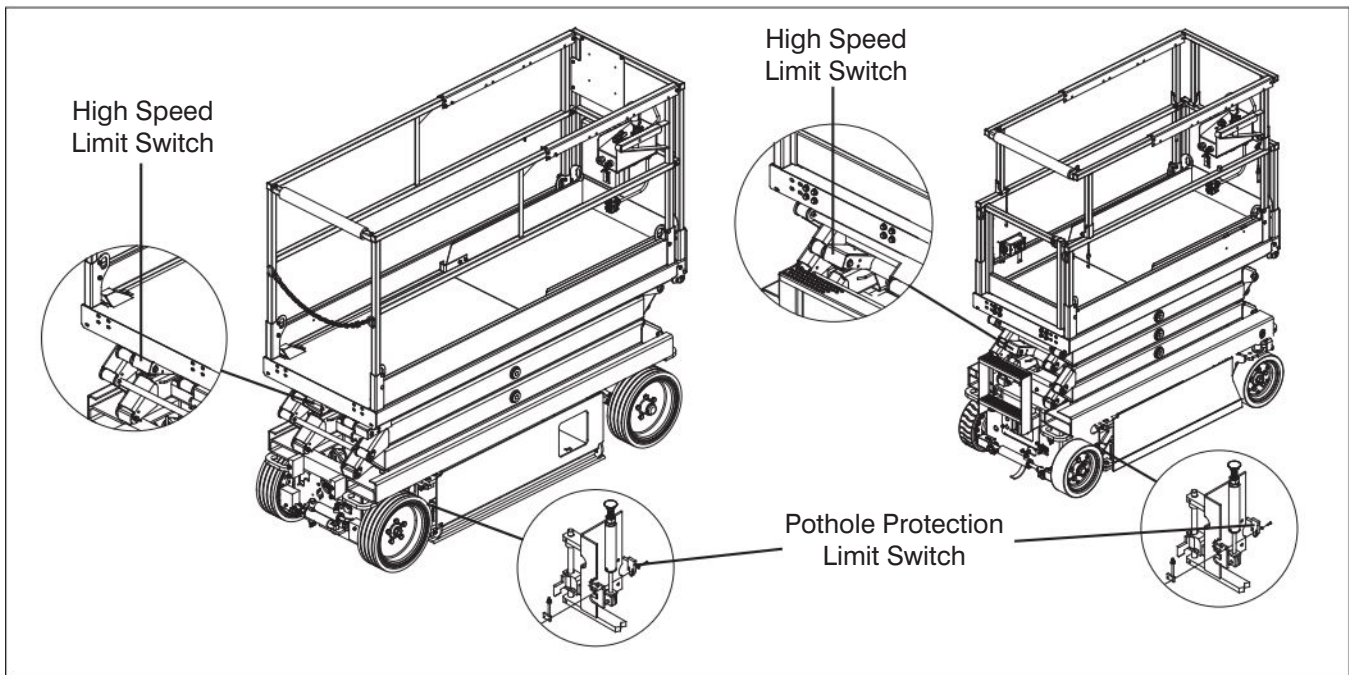

2.8 Visual & Daily Maintenance Inspections

Begin the visual and daily maintenance inspections by checking each item in sequence for the conditions listed in this section.



WARNING

To avoid injury, do not operate an aerial platform until all malfunctions have been corrected.



WARNING

To avoid possible injury, ensure aerial platform power is off during your visual and daily maintenance inspections.

NOTE

While performing visual and daily inspections in different areas, be aware to also inspect limit switches, electrical and hydraulic components.

2.8-1 Labels

Refer to the labels section in this manual and determine that all labels are in place and are legible.

2.8-2 Electrical

Maintaining the electrical components is essential to good performance and service life of the aerial platform.

Inspect the following areas for chafed, corroded and loose wires:

- base to platform cables and wiring harness
- battery tray wiring harnesses
- hydraulic/electrical wiring harnesses

2.8-3 Limit Switches

Ensure limit switches are properly secured with no signs of visible damage and movement is not obstructed.

2.8-4 Hydraulic

Maintaining the hydraulic components is essential to good performance and service life of the aerial platform.

Perform a visual inspection around the following areas:

- hoses and fittings
- all hydraulic cylinders
- all hydraulic manifolds
- the underside of the base
- ground area under the aerial platform

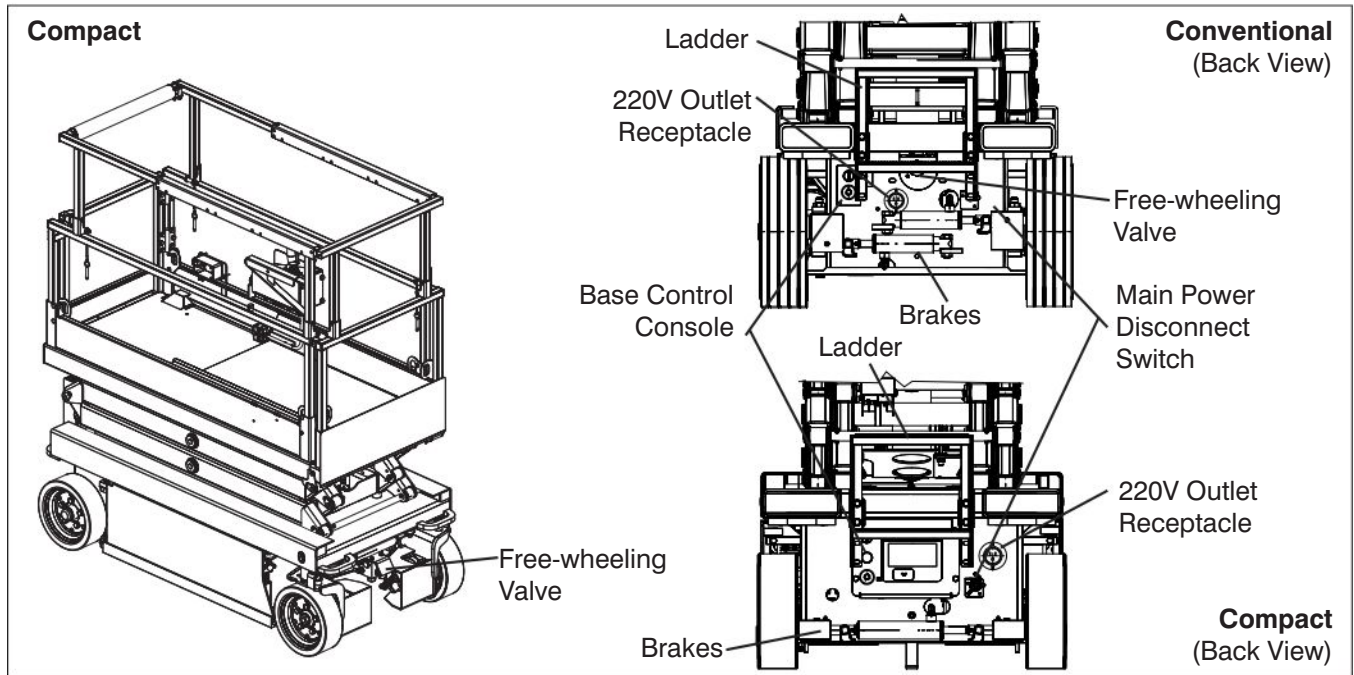

2.8-5 Entrance Side

- **Main Power Disconnect Switch**
 - Turn main power disconnect switch to “O” off position.
 - Ensure all cables are secure and switch is in proper working condition.
- **Base Control Switches**
 - Ensure there are no signs of visible damage and all switches are in their neutral positions.
- **Free-wheeling Valve Knob**
(Compacts - Front Side)
 - Ensure there are no loose or missing parts and there is no visible damage.
- **Brakes**
 - Ensure there are no loose or missing parts and there is no visible damage.
 - Ensure tabs are not locked.

- **220V Outlet Receptacle**
 - Ensure receptacle is free from dirt and obstructions.
- **Ladder**
 - Ensure there are no loose or missing parts and there is no visible damage.

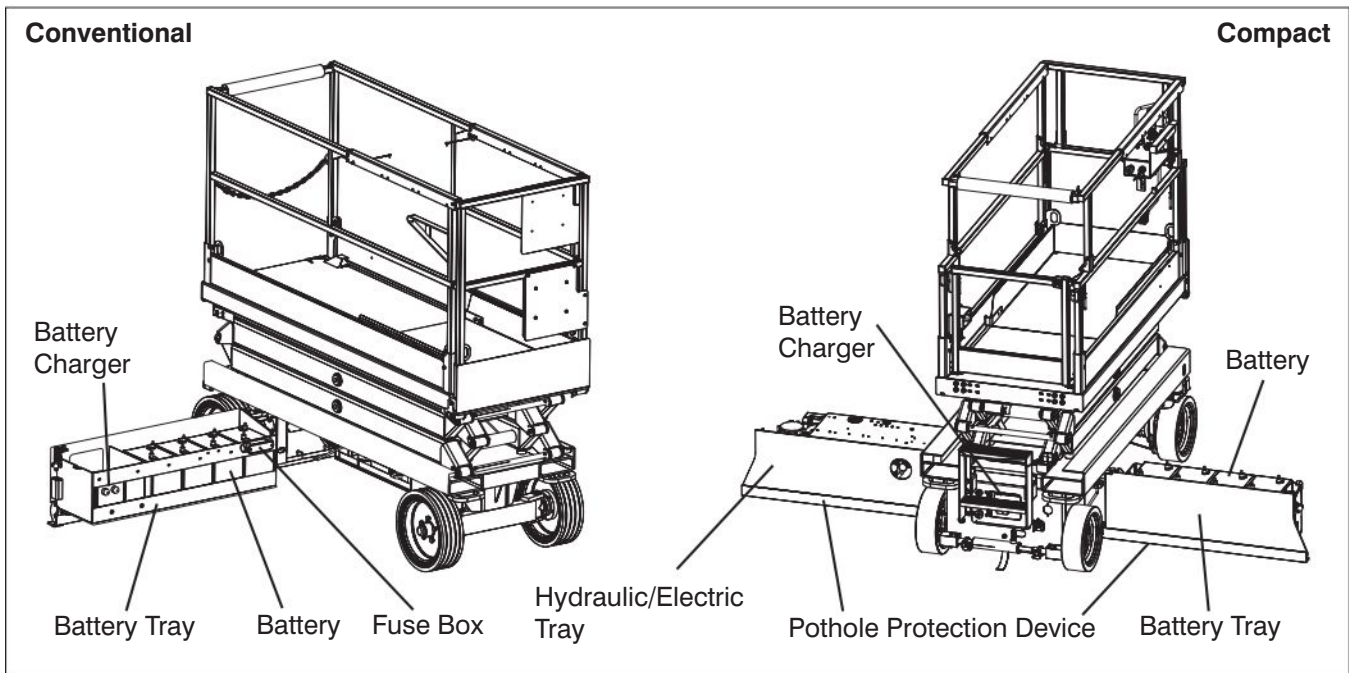

2.8-6 Battery Tray Side

- **Pothole Protection Device**
 - Ensure mechanisms have no sign of visible damage and are free from dirt and obstructions.
- **Battery Tray**
 - Ensure tray latch is secure and in proper working order.
- **Battery Charger**
(Compacts - Entrance Side)
 - Ensure charger is secure and shows no visible damage.
- **Battery**
Proper battery condition is essential to good performance and operational safety. Improper fluid levels or damaged cables and connections can result in component damage and hazardous conditions.



WARNING

Battery acid is extremely corrosive - Wear proper eye and facial protection as well as appropriate protective clothing. If contact occurs, immediately flush with cold water and seek medical attention.

1. Check battery case for damage.
2. Clean battery terminals and cable ends thoroughly with a terminal cleaning tool or wire brush.
3. Ensure all battery connections are tight.
4. If applicable, check battery fluid level. If plates are not covered by at least 13 mm of solution, add distilled or demineralized water.
5. Replace battery if damaged or incapable of holding a lasting charge.



WARNING

Explosion hazard. Keep flames and sparks away. Do not smoke near batteries.



WARNING

Use original or manufacturer-approved parts and components for the aerial platform.

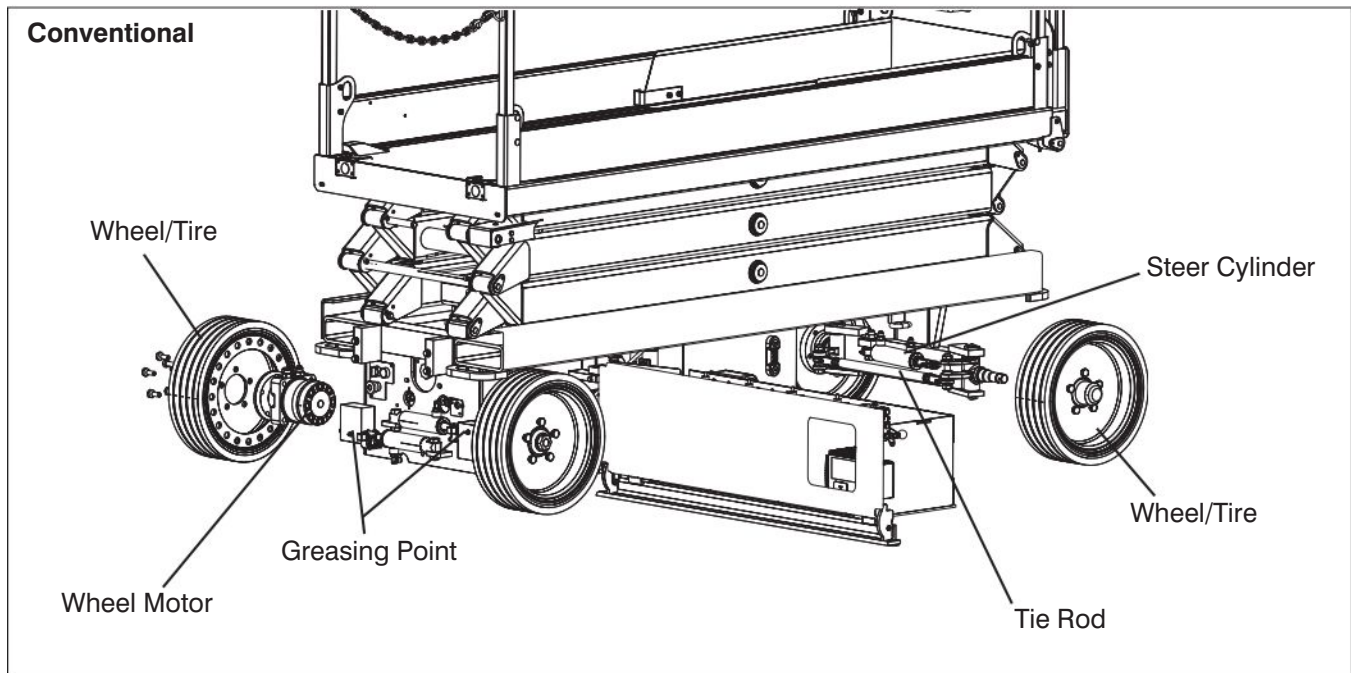

- **Steer Cylinder Assembly**
 - Ensure steer cylinder assembly is properly secured and there are no loose or missing parts.
- **Wheel/Tire Assembly**

The aerial platform is either equipped with solid rubber tires or foam-filled tires. Tire and/or wheel failure could result in an aerial platform tip-over. Component damage may also result if problems are not discovered and repaired in a timely fashion.

 - Check all tire treads and sidewalls for cuts, cracks, punctures and unusual wear.
 - Check each wheel for damage and cracked welds.
 - Check each lug nut for proper torque to ensure none are loose.
 - Check wheel motor assembly for loose or missing parts and signs of visible damage.
 - Ensure wheels are aligned and true vertically and horizontally.
- **Tie Rod (Conventionals)**
 - Ensure there are no loose or missing parts, tie rod end studs are locked and there is no visible damage.
- **Greasing Points**
 - Ensure greasing points have no sign of visible damage and are free from dirt and obstructions.

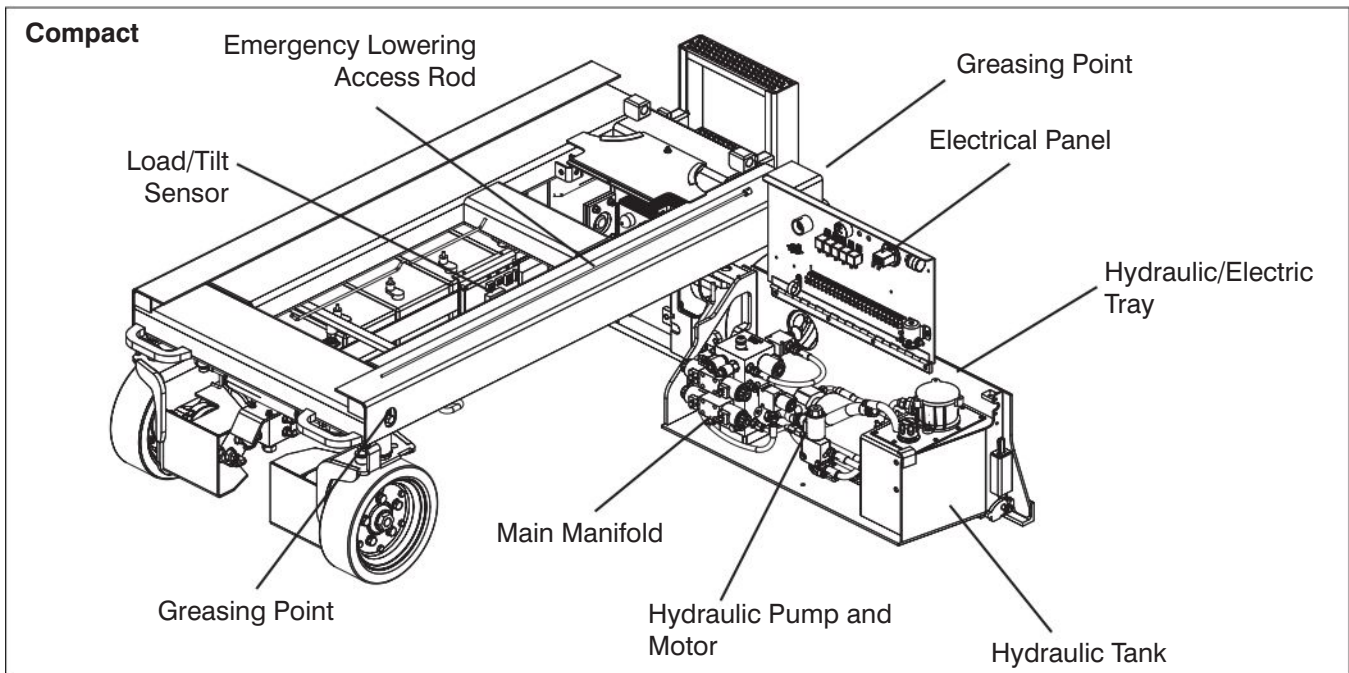

2.8-7 Hydraulic/Electric Tray Side

- Ensure tray latch is secure and in proper working order.
- **Pothole Protection Device**
 - Ensure mechanisms have no sign of visible damage and are free from dirt and obstructions.
- **Hydraulic Tank**
 - Ensure hydraulic filler cap is secure.
 - Ensure tank shows no visible damage and no evidence of hydraulic leakage.
- **Hydraulic Oil**
 - Ensure platform is fully lowered, and then visually inspect the sight gauge located on the side of the hydraulic oil tank.
 - The hydraulic oil level should be at or slightly above the top mark of the sight glass.
- **Hydraulic Pump and Motor**
 - Ensure there are no loose or missing parts and there is no visible damage.
- **Electrical Panel**
 - Ensure panel is properly secured and there is no visible damage.
 - Ensure there are no loose wires or missing fasteners.
- **Proportional and Main Manifolds**
 - Ensure all fittings and hoses are properly tightened and there is no evidence of hydraulic leakage.
 - Ensure there are no loose wires or missing fasteners.
- **Load/Tilt Sensor**
 - Ensure load/tilt sensor is properly secure and there is no visible damage.
- **Emergency Lowering Access Rod (If Equipped)**
 - Ensure rod is properly secured and there is no visible damage.

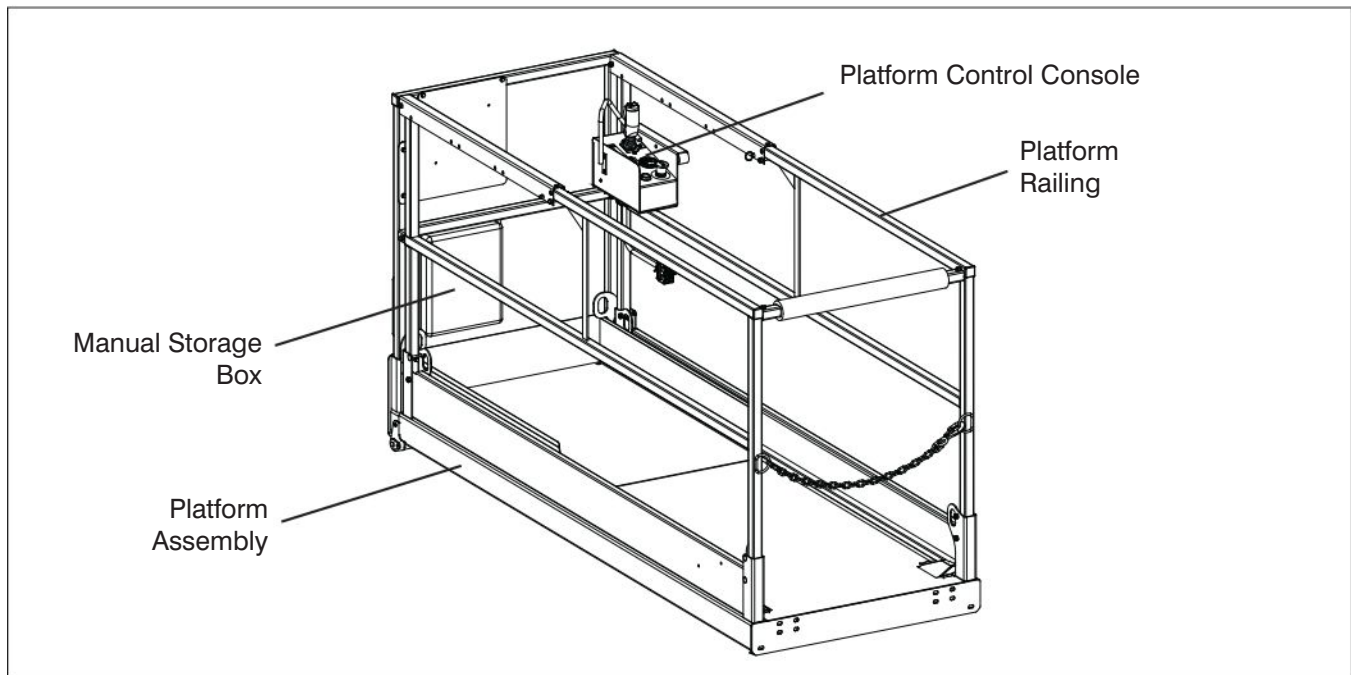

2.8-8 Platform Assembly



WARNING

Ensure that you maintain three points of contact to mount/dismount platform.

1. Use the ladder of aerial platform to access platform.
 2. Close the gate.
 - Ensure there are no loose or missing parts and there is no visible damage.
 - Ensure all fasteners are securely in place.
 - Ensure all railings are properly positioned and secured.
 - Ensure gate is in good working order.
- **Lanyard Attachment Anchors**
 - Ensure attachment rings are secure and no visible damage.
 - **AC Outlet on Platform**
 - Ensure outlet has no visible damage and free from dirt or obstructions.
 - **Platform Control Console**
 - Ensure all switches and controller are returned to neutral and are properly secured.
 - Ensure there are no loose or missing parts and there is no visible damage.
 - **Manuels**
 - Ensure a copy of operating manual and CE certificate are enclosed in manual storage box.
 - Check to be sure manual storage box is present and in good condition.
 - Ensure manuals are legible and in good condition.
 - Always return manuals to the manual storage box after use.

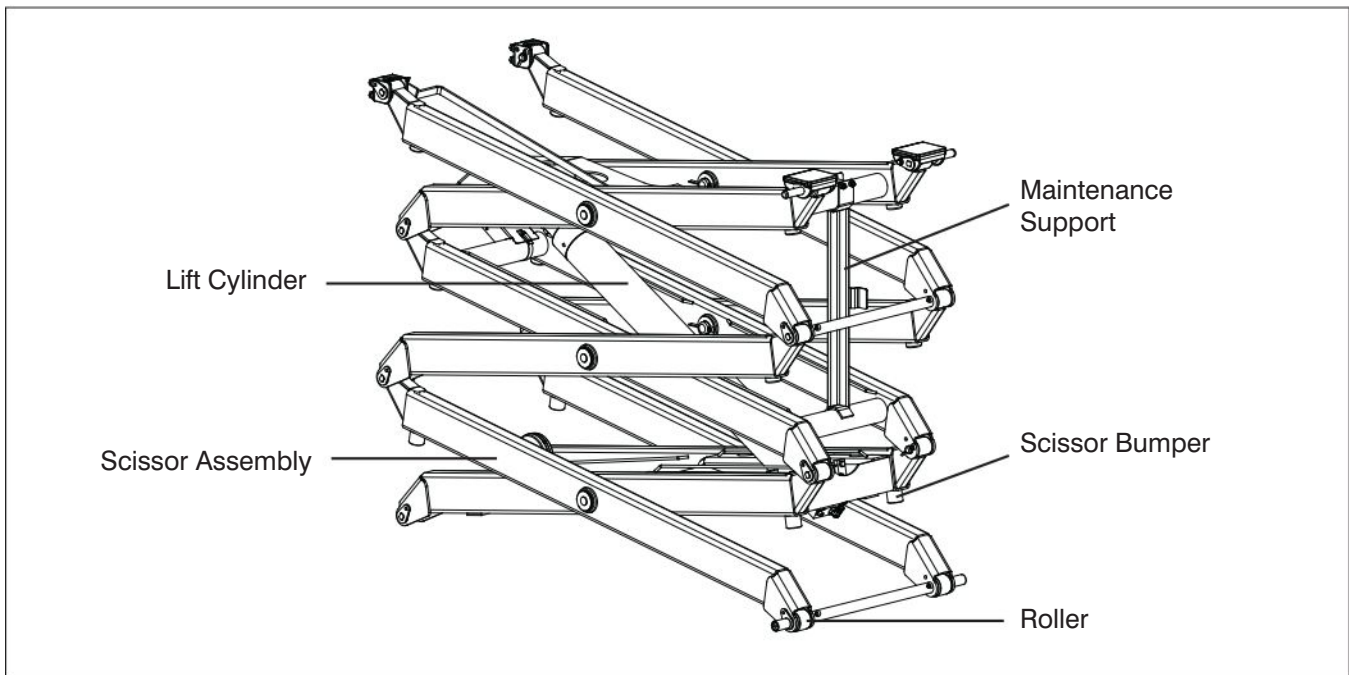

- **Powered Extension Control Console (If Equipped)**
 - Ensure all switches are returned to neutral and are properly secured.
 - Ensure there are no loose or missing parts and there is no visible damage.



WARNING

Ensure that you maintain three points of contact to mount/dismount platform.

3. Use the ladder to dismount from platform.

2.8-9 Lifting Mechanism

1. Raise the platform (refer to Section 2.10-2) until there is adequate clearance to swing down the maintenance support (refer to Section 2.16).

- **Maintenance Support**
 - Ensure maintenance support is properly secured and shows no visible damage.
- **Scissor Assembly**
 - Ensure scissor assembly shows no visible damage and no signs of deformation in weldments.
 - Ensure all pins are properly secured.

- Ensure cables and wires are properly routed and shows no signs of wear and/or physical damage.
 - **Scissor Bumpers**
 - Ensure bumpers are secure and shows no sign of visible damage.
 - **Rollers**
 - Ensure rollers are secure and there is no visible damage.
 - Ensure rollers' path of travel are free from dirt and obstructions.
 - **Lift Cylinder(s)**
 - Ensure each lift cylinder is properly secured, there are no loose or missing parts and there is no evidence of damage.
 - Ensure all fittings and hoses are properly tightened and there is no evidence of hydraulic leakage.
1. Raise the platform until there is adequate clearance to swing up the maintenance support.
 2. Swing up maintenance support into storage bracket.
 3. Fully lower the platform.

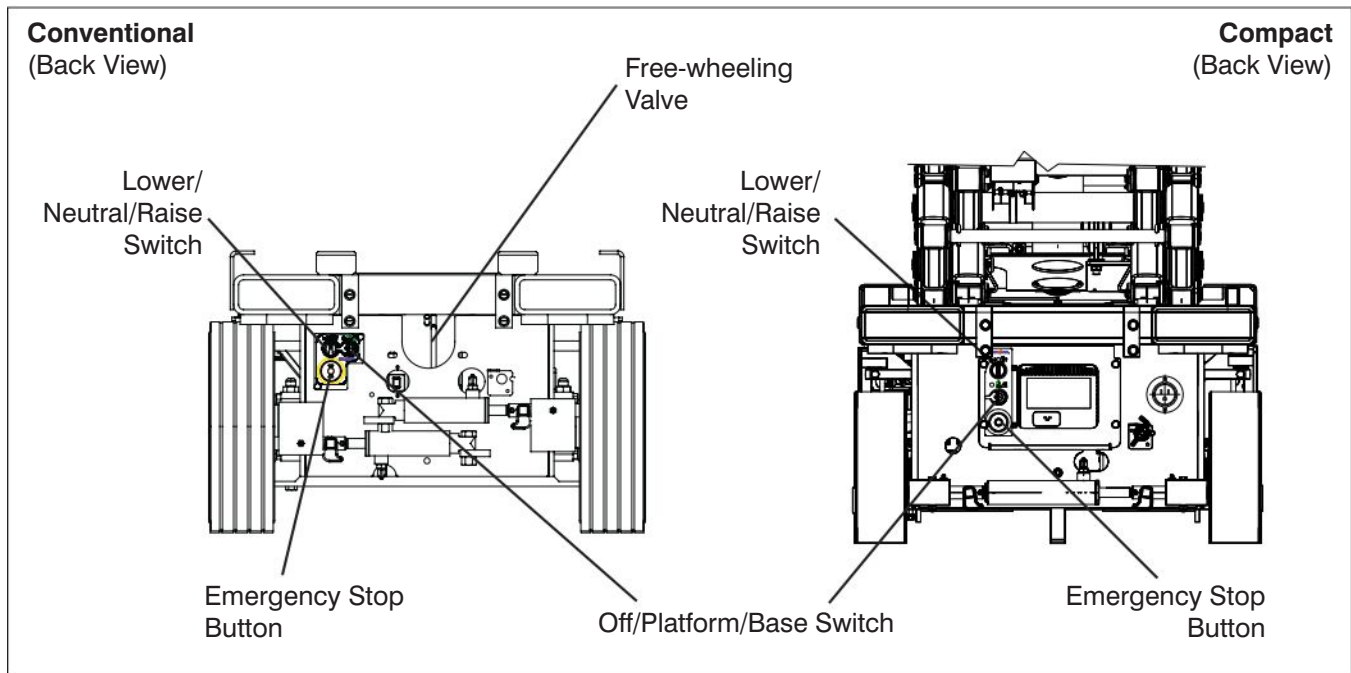

2.9 Function Tests

Function tests are designed to discover any malfunctions before aerial platform is put into service. The operator must understand and follow step-by-step instructions to test all aerial platform functions.



WARNING

Never use a malfunctioning aerial platform. If malfunctions are discovered, aerial platform must be tagged and placed out of service. Repairs to aerial platform may only be made by a qualified service technician.

After repairs are completed, operator must perform a pre-operation inspection and a series of function tests again before putting aerial platform into service.

Prior to performing function tests, be sure to read and understand Section 2.10 - Start Operation.

2.9-1 Test Main Power Disconnect Switch

1. At rear of the base, turn main power disconnect switch to “○” off position.
Result: Aerial platform functions should not operate.

2.9-2 Base Control Console



WARNING

Ensure that you maintain three points of contact when using the ladder to mount/dismount platform.

1. Use the ladder of aerial platform to access platform.
2. Close the gate.
3. On platform control console, pull out “○” emergency stop button.
4. Use the ladder to dismount from platform.
5. Turn main power disconnect switch to “|” on position.

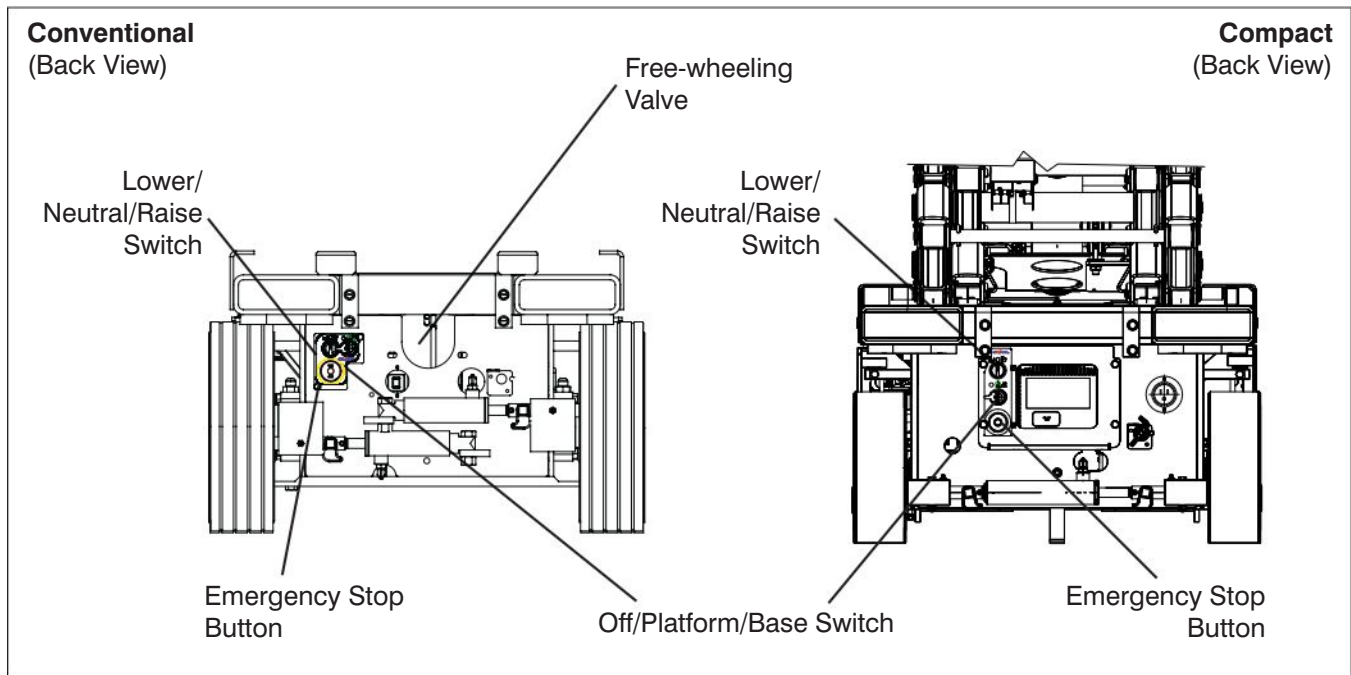

• **Test Base Emergency Stop**

1. Push in base “” emergency stop button and attempt to raise or lower the platform.
Result: Platform raising and lowering functions should not operate.

2. Pull out base “” emergency stop button.

• **Test Off/Platform/Base Switch**





WARNING
Be aware of overhead obstructions or other possible hazards around the aerial platform when lifting.



1. Select off/platform/base key switch “” off position. Attempt to raise or lower the platform.
Result: Platform raising and lowering functions should not operate.

2. Select off/platform/base key switch to “” platform position. Attempt to raise or lower the platform.
Result: Platform raising and lowering functions should not operate.

3. Select and hold off/platform/base key switch to “” base position. Attempt to raise or lower the platform.
Result: Platform raising and lowering functions should operate.

• **Test Lower/Neutral/Raise Switch**

1. Select and hold off/platform/base key switch to “” base position and “” raise the platform with lower/neutral/raise switch.
Result: Platform should rise.

2. Select and hold off/platform/base key switch to “” base position and “” lower the platform with lower/neutral/raise switch.
Result: Platform should lower.

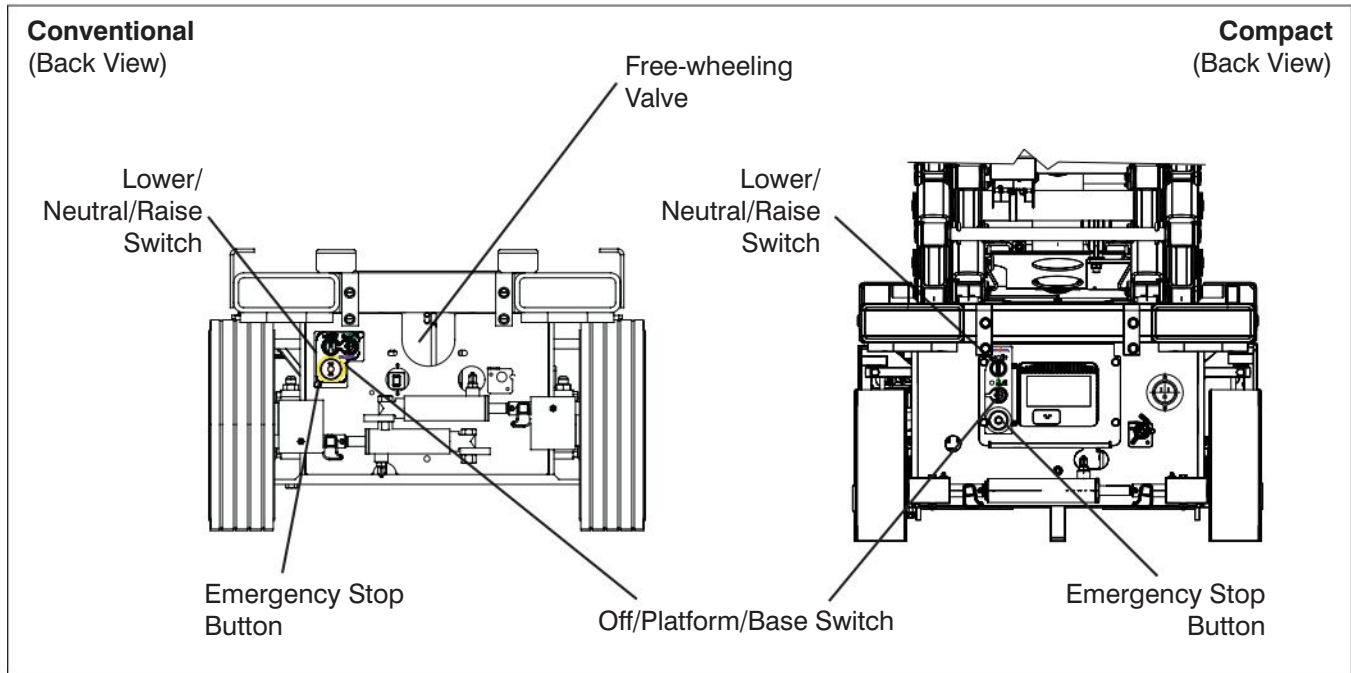

- **Test Emergency Lowering**



1. Raise the platform.
2. Locate holding valve manual override knob at the base of each lift cylinder. Depress and turn counterclockwise. If necessary, use access rod that is located on the base of the aerial platform.
3. On hydraulic/electric tray, pull out and hold emergency lowering valve to fully lower the platform.
Result: The platform should lower.
4. To restore normal operation, depress and turn holding valve manual override knobs clockwise.

- **Test Free-wheeling**

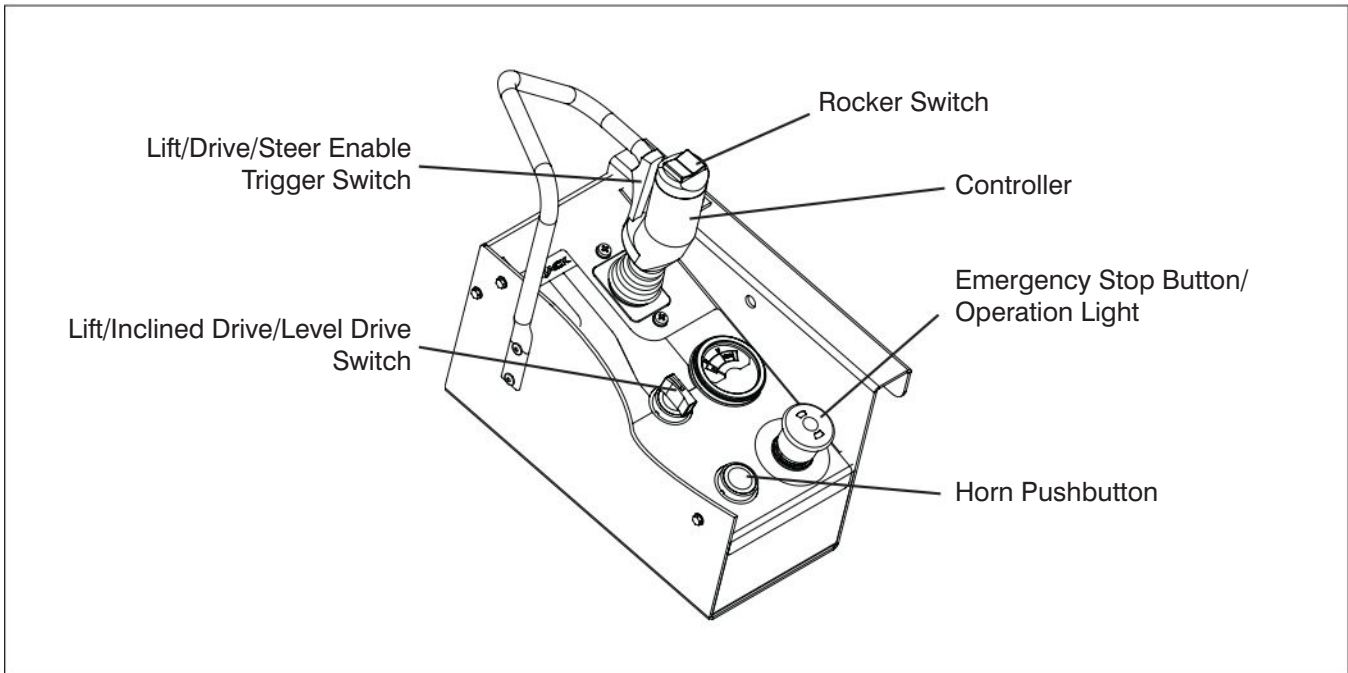
1. Ensure path of intended motion is clear.
2. Release the brake manually (refer to Section 2.14-2).
3. Turn free-wheeling valve knob counterclockwise to a fully opened position and attempt to push/pull the aerial platform.
Result: Platform should move
4. Turn free-wheeling valve knob clockwise to a fully closed position for normal operation.
5. Reengage the brake (refer to Section 2.14-2).



2.9-3 Platform Control Console

1. Ensure base “” emergency stop button is pulled out.
2. Select off/platform/base key switch to “” platform position.
3. Ensure main power disconnect switch is in “” on position.



WARNING

Ensure that you maintain three points of contact when using the ladder to mount/dismount platform.

4. Use the ladder of aerial platform to access platform.
5. Close the gate.
6. On platform control console, pull out “” emergency stop button.





• **Test Platform Emergency Stop**

1. Push in “” emergency stop button and attempt to activate any platform function.
Result: All selected platform functions should not operate.

• **Test Enable Trigger Switch**



1. Pull out “” emergency stop button.
2. Without activating “” enable trigger switch, attempt to activate each platform function.
Result: All platform functions should not operate.



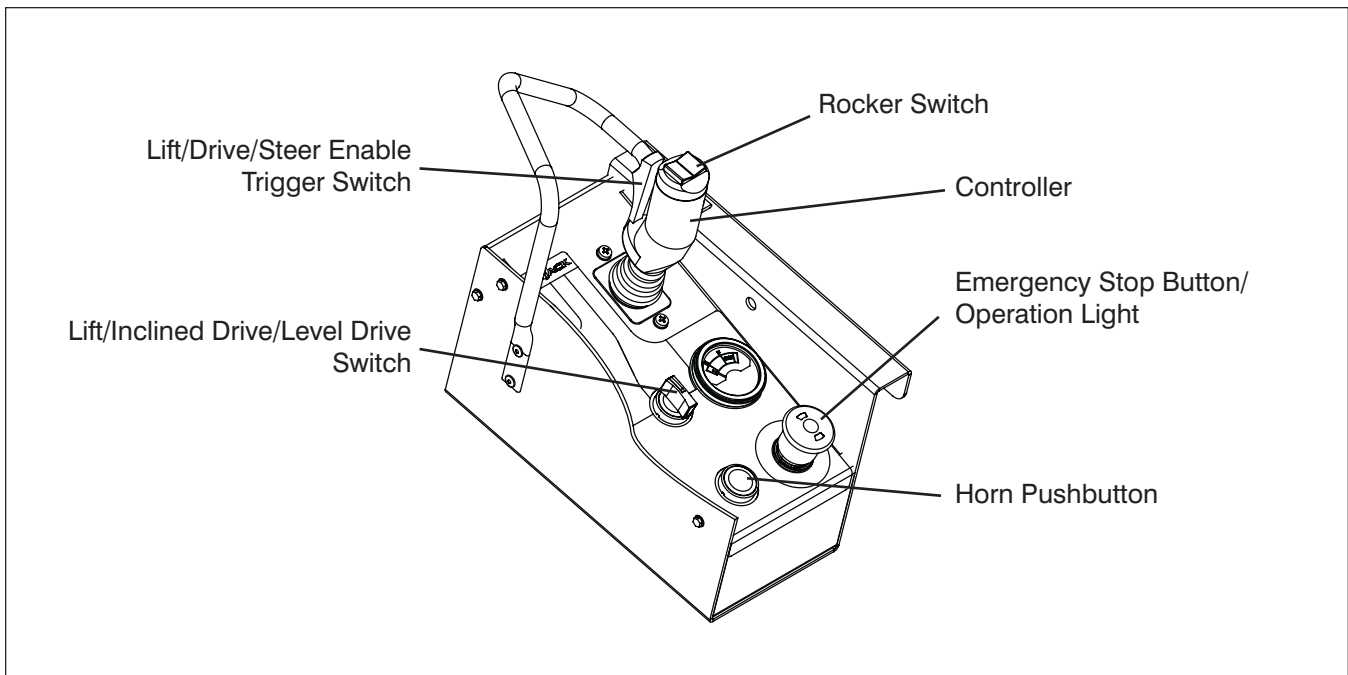



• **Test Steering**

1. Select lift/inclined drive/level drive switch to either “” inclined drive (low speed/high torque) or “” level drive (high speed/low torque) position.
2. Activate and hold “” enable trigger switch.
3. Press rocker switch on top of controller handle to “” left and “” right.
Result: Steer wheels should turn left and right.



• **Test Driving**

1. Ensure path of intended motion is clear.
2. Activate and hold “” enable trigger switch.
3. Slowly move controller handle in “” forward direction until aerial platform begins to move, and then return handle to center position.
Result: Aerial platform should move in forward direction, and then come to a stop.
4. Slowly move controller handle in “” reverse direction until aerial platform begins to move, and then return handle to center position.
Result: Aerial platform should move in reverse direction, and then come to a stop.

1. Ensure path of intended motion is clear.
2. Activate and hold “” enable trigger switch.
3. Drive aerial platform “” forward and then “” backward. Test brake by releasing controller handle.
Result: Aerial platform should come to a stop. If aerial platform pulls to one side while stopping, do not operate aerial platform until brake adjustments have been checked.
4. Drive aerial platform “” forward and then “” backward. Test brake again by releasing “” enable trigger switch only.
Result: Aerial platform should come to an instant and abrupt stop. If aerial platform does not stop immediately, or if aerial platform pulls to one side while stopping, do not operate aerial platform until brake adjustments have been checked.

• **Test Brakes**



WARNING
Brakes will engage instantly when you release the controller handle, causing aerial platform to stop immediately.

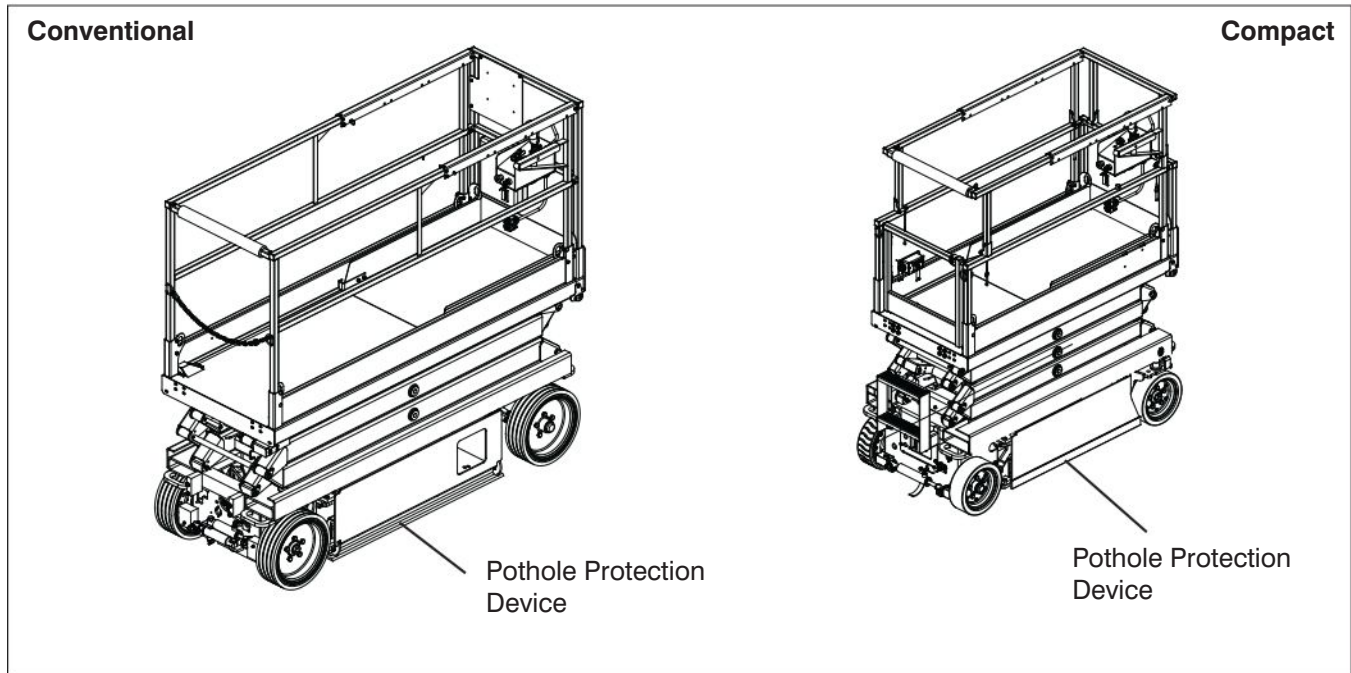

• **Test Platform Raising/Lowering**



WARNING
 Be aware of overhead obstructions or other possible hazards around the aerial platform when lifting.

1. Select lift/ inclined drive/level drive switch to “” lift position.
2. Activate and hold “” enable trigger switch.
3. Push controller handle and raise the platform to an approximate height of 0.5 meter.
Result: Platform should rise.
4. Pull controller handle and lower the platform fully.
Result: Platform should lower.

• **Test Lowering Warning**

1. Raise the platform until approximately a height of 3 to 4 meters is reached then attempt to fully lower the platform.
Result: Platform should stop lowering at a height of 2.5 meters high and an alarm should sound.
2. Release controller handle.

• **Test Horn**

1. Push “” horn pushbutton.
Result: Horn should sound.

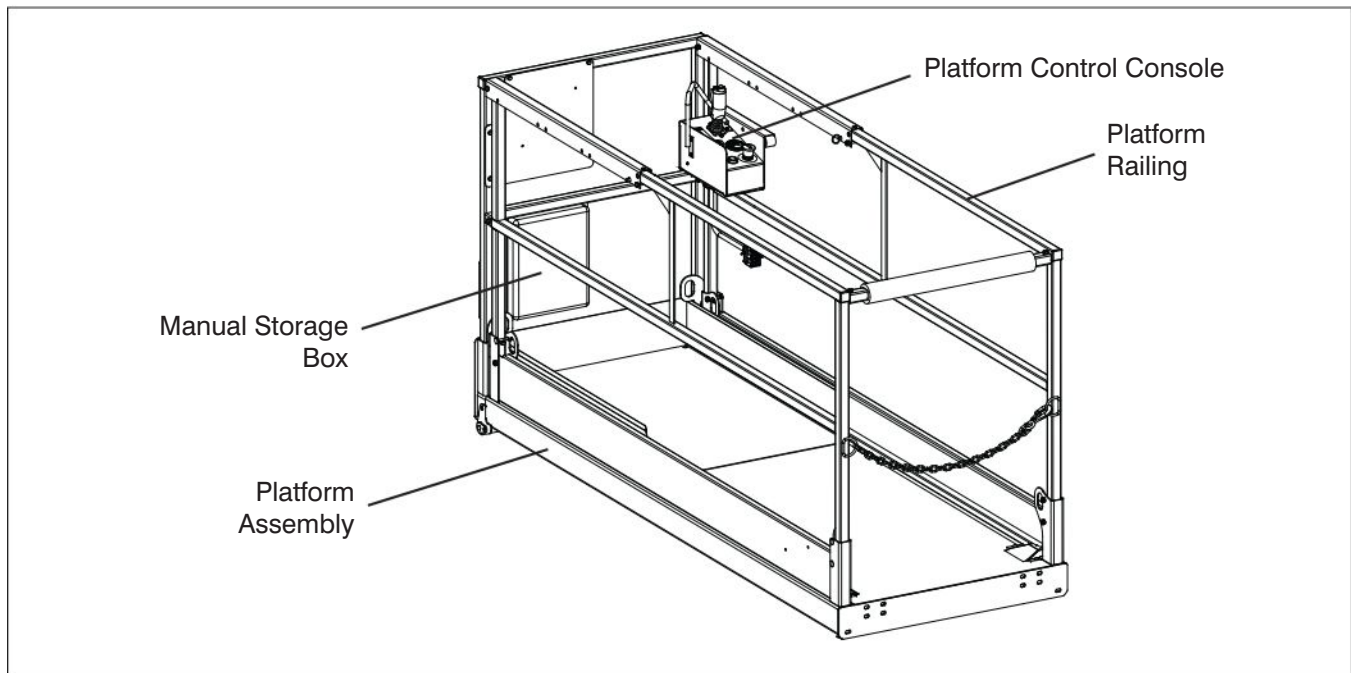

- **Test Pothole Sensor**

**WARNING**

Ensure that you maintain three points of contact to mount/dismount platform.

1. Use the ladder to dismount from platform and place a block, approximately 3.75 cm, under the hydraulic/electric tray.
2. Use the ladder of aerial platform to access platform.
3. Close the gate.
4. Raise the platform until approximately a height of 2 meters is reached and attempt to drive forward or reverse.
Result: Aerial platform should not move forward or backward.
5. Repeat the steps above with block placed under battery tray.
Result: Aerial platform should not move forward or backward.

- **Test Speed Limit**

**WARNING**

Be aware of overhead obstructions or other possible hazards around the aerial platform when lifting.

1. Ensure path of intended motion is clear.
2. Raise the platform until approximately a height of 2 meters is reached and attempt to drive forward or reverse.
Result: Aerial platform should move slower than when it was in stowed position.

2.10 Start Operation

Carefully read and completely understand the operating manual and all warnings and instruction labels (refer to labels section) on the aerial platform.



WARNING

Do not operate this aerial platform without proper authorization and training. Failure to avoid this hazard could result in death or serious injury.

Before operating this aerial platform, perform the following steps:

1. Visual and daily maintenance inspections (see Section 2.8)
2. Function tests (see Section 2.9)
3. Jobsite inspection
It is the responsibility of the operator to perform a jobsite inspection and avoid the following hazardous situations:
 - holes or drop-offs
 - ditches or soft fills
 - floor obstructions, bumps or debris
 - overhead obstructions
 - electrical cords, hoses and high voltage conductors
 - hazardous locations
 - inadequate surface support to withstand all load forces imposed by the aerial platform
 - wind and weather conditions
 - the presence of unauthorized personnel
 - other possible unsafe conditions



WARNING

An operator should not use any aerial platform that:

- does not appear to be working properly.
- has been damaged or appears to have worn or missing parts.
- has alterations or modifications not approved by the manufacturer.
- has safety devices which have been altered or disabled.



Failure to avoid these hazards could result in death or serious injury.

2.10-1 To Activate Base Control Console



WARNING

Ensure that you maintain three points of contact when using the ladder to mount/dismount platform.

1. Use the ladder of aerial platform to access platform.
2. Close the gate.
3. On platform control console, pull out “” emergency stop button.
4. Use the ladder to dismount from platform.
5. Turn main power disconnect switch to “I” on position.
6. On base control console, pull out “” emergency stop button.

2.10-2 To Raise or Lower Platform Using Base Control Console





WARNING

Be aware of overhead obstructions or other possible hazards around the aerial platform when lifting.



WARNING

Do not lower the platform unless the area is clear of personnel and obstructions.

1. Activate base control console (refer to Section 2.10-1).
2. Select and hold off/platform/base key switch to “” base position.
3. Select and hold lower/neutral/raise switch to either “” raise or “” lower position. Release switch to stop.

Lowering Warning System - A lowering warning system automatically stops lowering function before reaching fully retracted position and sounds the alarm. After the operator has released down controls and taken time to check that no person is near the scissors, the lowering function can be reactivated.

2.10-3 To Activate Platform Control Console

1. Turn main power disconnect switch to “I” on position.
2. On base control console, pull out “O” emergency stop button.
3. Select off/platform/base key switch to “” platform position.



WARNING

Ensure that you maintain three points of contact when using the ladder to mount/dismount platform.

4. Use the ladder of aerial platform to access platform.
5. Close the gate.
6. On platform control console, pull out “O” emergency stop button.

2.10-4 To Raise or Lower Platform Using Platform Control Console





WARNING

Be aware of overhead obstructions or other possible hazards around the aerial platform when lifting.



WARNING

Do not lower the platform unless the area below is clear of personnel and obstructions.

1. Activate platform control console (refer to Section 2.10-3).
2. On platform control console, select lift/inclined drive/level drive switch to “” lift position.
3. Activate and hold “” enable trigger switch.
4. Move controller handle forward or backward until desired height is reached.

NOTE

Lowering is not proportional.

Lowering Warning System - A lowering warning system automatically stops the lowering function before reaching the fully retracted position and sounds the alarm. After the operator has released the down controls and taken time to check that no person is near the scissors, the lowering function can be reactivated.

5. Return controller to neutral center position to stop. Release “” enable trigger switch.



WARNING

To protect against unintended movement of the aerial platform, push in the emergency stop button after you have arrived at your desired location or elevation.

NOTE

If the tilt alarm sounds and the platform does not, or only partially raises, immediately lower the platform completely and ensure that the aerial platform is on a firm level surface.







2.10-5 To Drive Forward or Backward

**WARNING**

Be aware of blind spots when operating the aerial platform.

**WARNING**





Ensure that there are no personnel or obstructions in the path of travel, including blind spots.

1. Activate platform control console (refer to Section 2.10-3).
2. On platform control console, select lift/inclined drive/level drive switch to either “” inclined drive (low speed/high torque) or “” level drive (high speed/low torque) position.
3. Activate and hold “” enable trigger switch.
4. Move controller handle “” forward/up or “” backward/down to desired speed and direction of aerial platform travel.
5. Return controller to neutral center position to stop. Release “” enable trigger switch.

**WARNING**

To protect against unintended movement of the aerial platform, push in the emergency stop button after you have arrived at your desired location or elevation.

2.10-6 To Steer

1. Activate platform control console (refer to Section 2.10-3).
2. On platform control console, select lift/inclined drive/level drive switch to either “” inclined drive (low speed/high torque) or “” level drive (high speed/low torque) position.
3. Activate and hold “” enable trigger switch.
4. Press “” rocker switch on top of controller handle in either direction to steer.

NOTE

Steering is not proportional. Driving and steering may be active at the same time.

2.10-7 To Select Level Drive or Inclined Drive Mode

1. **Level Drive Mode:** Select level drive mode when traveling on flat surface. To activate level drive mode, select lift/inclined drive/level drive switch to “” level drive (high speed/low torque) position.



WARNING

Aerial platform must be in fully retracted position when operated on any grade. Driving while elevated on any grade may result in death or serious injury.

2. **Inclined Drive Mode:** Select inclined drive mode when climbing grades or when loading or unloading the aerial platform. To activate inclined drive mode, select lift/inclined drive/level drive switch to “” inclined drive (low speed/high torque) position.



WARNING

To protect against unintended movement of the aerial platform, push in emergency stop button after you have arrived at your desired location or elevation.

2.10-8 To Extend/Retract Manual Extension Platform



DANGER

Crushing Hazard - Extension platform must not be retracted manually from the ground.

1. To extend/retract manual extension platform, remove retaining locking pins and push/pull extension platform using the push bar or sliding handrails to one of four or five desired locking positions.
2. Upon extension or retraction, reinsert locking pins. Insert pin on one side of aerial platform in front of upright bar and the pin on the other side of aerial platform behind the upright bar to prevent accidental movement, in either direction, of manual extension platform during travel or transport. Refer to Figure 2-15 for a configuration example.

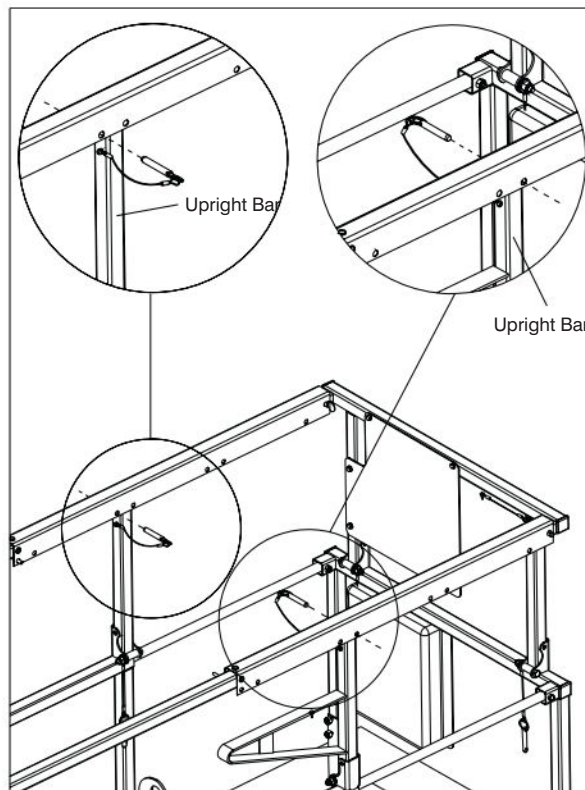







Figure 2-15. Variable Position Manual Extension Platform

2.10-9 To Extend/Retract Powered Extension Platform (If Equipped)



1. To extend/retract powered extension platform, ensure “” emergency stop button is pulled out.
2. On platform control console, select lift/inclined drive/level drive switch to “” lift position.
3. On powered extension control console, press and hold “” enable switch, then push extend/retract switch to “” extend position. Release switch to stop.
4. To retract extension platform, press and hold “” enable switch, then push extend/retract switch to “” retract position. Release switch to stop.



WARNING

To protect against unintended movement of the aerial platform, push in emergency stop button after you have arrived at your desired location or elevation.

2.10-10 Electrical Inverter (If Equipped)

1. Turn main power disconnect switch to “” on position.
2. Make sure on/off switch of the inverter is “” on position.
3. Inverter state is indicated by the LEDs on the face of the inverter. A glowing green LED indicates normal operation. If a fault occurs, the status LEDs will indicate the area responsible.



CAUTION

The main power disconnect switch must be turned off at the end of the shift or the batteries will drain.



2.10-11 Shutdown Procedure

1. Completely lower the platform.
2. On platform control console, push in “” emergency stop button.



WARNING

Ensure that you maintain three points of contact when using the ladder to mount/dismount platform.

3. Use the ladder to dismount from platform.
4. On base control console, select off/platform/base key switch to “” off position and remove the key.
5. Turn main power disconnect switch to “” off position.

2.11 Guardrail Folding Procedure

When folder down, the folding guardrail system reduces the height of the retracted aerial platform for transporting only.



WARNING

Any lowered guardrail will create a fall hazard. Remain away from the side of the platform while raising or lowering the guardrails to avoid falling.

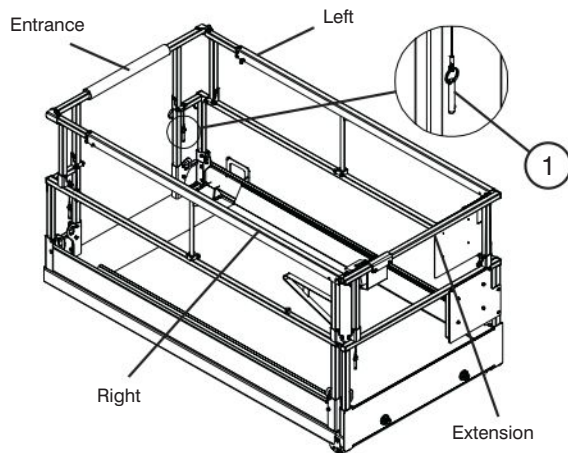

Figure 2-16a. Folding Guardrail System

1. **Guardrail Locking Pin with Lanyard** - This pin is used to lock the guardrail in place.



WARNING

The scissor assembly must be fully lowered before raising or lowering the guardrails.



WARNING

Before operating this aerial platform check the guardrail system for loose or missing locking pins. The guardrail system must be upright and all pins must be locked in place. Death or serious injury could result if the guardrail system is not upright or properly locked.

To fold the guardrail system down:

1. Ensure aerial platform is on level ground.
2. Use the ladder of aerial platform to access platform.
3. Close the gate.
4. Remove the platform control console and outrigger control console (if equipped) and lay it down on the platform.
5. Remove all locking pins.
6. Fold guardrails down in the following order: right-hand side, left-hand side, entrance and extension (refer to Figure 2-16a).
7. Lock in place on the mounting post using the locking pin (refer to Figure 2-16b). Ensure that the detent ball of the pin is all the way through.

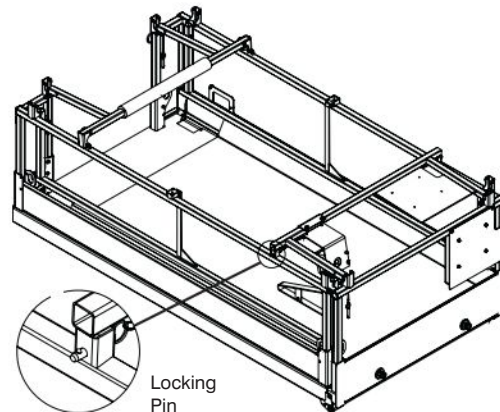

Figure 2-16b. All Guardrails Folded Down

To raise the guardrail system up:

1. Ensure aerial platform is on level ground.
2. Use the ladder of aerial platform to access platform.
3. Remove all locking pins.
4. Raise guardrails up in the following order: extension, entrance, left-hand side and right-hand side.
5. Lock each guardrail in place with the locking pins ensuring that the detent ball of each pin is all the way through. See Figure 2-16b.
6. Mount the platform control console and outrigger control console (if equipped) at the front right of the platform. Lock them in place.

2.12 Loading/Unloading

Know and heed all national, state or territorial/provincial and local rules which apply to your loading/unloading of aerial platforms.

Only qualified personnel shall operate machinery during loading/unloading.

Be sure vehicle capacity and loading equipment hoists, chains, straps, etc., are sufficient to withstand maximum aerial platform weight.

The transport vehicle must be parked on a level surface and must be secured to prevent rolling while aerial platform is being loaded/unloaded.

2.12-1 Lifting



WARNING

Only qualified rigger shall operate machinery during lifting.

When it is necessary to lift the aerial platform the following conditions must be met:

- The platform must be fully lowered.
- The main power disconnect switch must be in “O” off position.
- The hydraulic/electric and battery trays must be closed and securely latched.
- The extension platform must be retracted and secured.
- The platform control console must be secured to the railings or removed.
- The platform must be cleared of all personnel, tools and materials.
- The lifting/rigging may be attached to all four lifting points as illustrated in Figure 2-17.

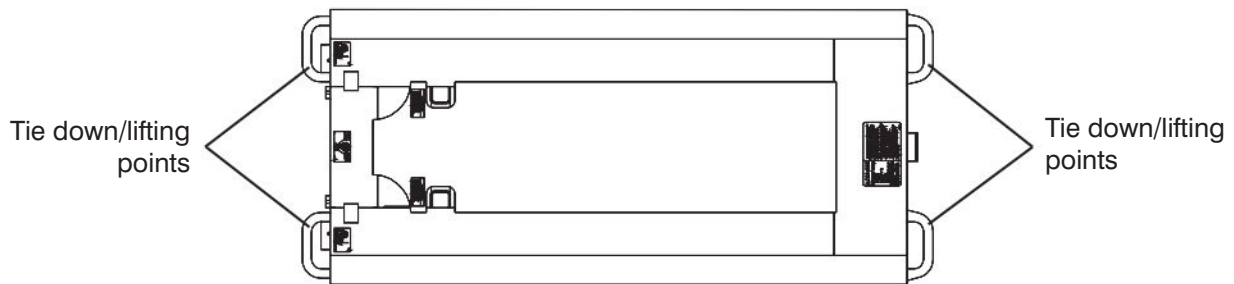

Figure 2-17. Tie Downs/Lifting Points



Figure 2-18. Center of Gravity

NOTE

The mass of the aerial platform is as per [Table 2-3a](#) or [Table 2-3b](#). The center of gravity is approximately located in the middle of the aerial platform, front to back and side to side, as illustrated in Figure 2-18. Vertically, the center of gravity is approximately just above the base chassis.

NOTE

The aerial platform can be lifted with a forklift from the sides but Skyjack does not recommend this use. Lift with forks in designated pockets as illustrated in Figure 2-19.

2.12-2 Driving

Before driving the aerial platform:

- Ramp or dock capacity must be sufficient to withstand maximum aerial platform weight.
- Ramp should be equipped with side guards to prevent inadvertent fall from the ramp.
- Incline should not exceed aerial platform gradeability (refer to [Table 2-3a](#) or [Table 2-3b](#)).
- Aerial platform brake must be checked for proper operation.
- Aerial platform speed should be on high torque setting (if equipped).

**WARNING**

When transporting, the aerial platform must be secured to the truck or trailer deck. Tie downs are available as illustrated in [Figure 2-17](#).

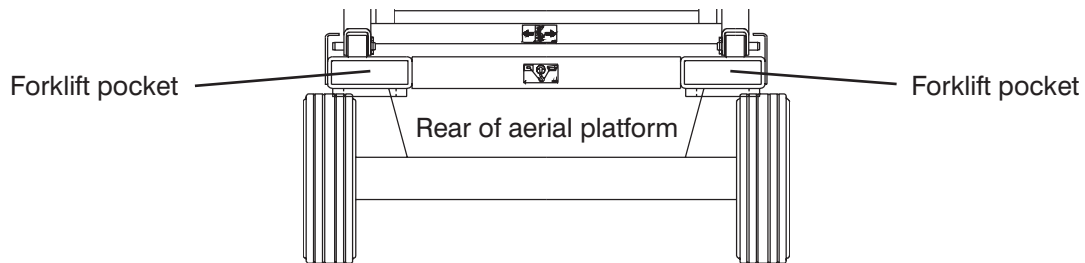

Figure 2-19. Forklift Pockets

2.13 Moving the Aerial Platform Through a Doorway



WARNING

This procedure is suitable for level ground only.

1. Confirm that the height/width of the doorway is sufficient to allow the aerial platform to pass through.

NOTE

If it is necessary to fold the guardrails, refer to Section 2.11 for guardrail folding procedure.

2. Perform a thorough jobsite inspection prior to operating the aerial platform to identify potential hazards in your work area.
3. Cordon-off the pathway which you intend to travel.
4. Position the aerial platform to allow all future motion, including through the doorway, to be in a forward direction.
5. Turn main power disconnect switch to “○” off position.
6. Use the ladder of aerial platform to access platform.





WARNING

Ensure that you maintain three points of contact when using the ladder to mount/dismount platform.

7. Close the gate. On platform control console, push in “○” emergency stop button.
8. Disconnect and remove platform control console from the platform.
9. Fold the guardrails if necessary. Refer to Section 2.11 for guardrail folding procedure.
10. Use the ladder to dismount from platform.
11. Connect platform control console to the connection at the rear of the base.

NOTE

For some models, the connection is located beneath an access panel which requires that the scissor assembly be raised to access it.

12. Ensure there are no personnel in the intended path of travel.
13. Notify those around the pathway that you will be moving the aerial platform.
14. Use a spotter to guide movement. Ensure the spotter remains at a safe distance.
15. Ensure that platform control console is properly oriented in the direction the aerial platform is facing.
16. Turn main power disconnect switch to “I” on position.
17. On base control console, pull out “○” emergency stop button.
18. Select base/off/platform key switch to “” platform position.
19. On platform control console, pull out “○” emergency stop button.
20. Select lift/inclined drive/level drive to “” inclined drive (low speed/high torque) position for reduced speed.



WARNING

Do not drive the aerial platform toward yourself.

21. Using as low a speed as practical and the operator positioned behind the aerial platform, drive forward through doorway.
22. Once safely through doorway, push in “○” emergency stop button and turn main power disconnect switch to “○” off position.
23. Disconnect platform control console and return it to the platform.

**WARNING**

Ensure that you maintain three points of contact when using the ladder to mount/dismount platform.

24. Return guardrails to upright position if folded. Refer to Section 2.11 for guardrail folding procedure.

**WARNING**

Before operating this aerial platform check the guardrail system for loose or missing locking pins. The guardrail system must be upright and all pins must be locked in place.

Death or serious injury could result if the guardrail system is not upright or properly locked.

25. Once the platform control console is securely reconnected and guardrails up, normal operation may continue.

2.14 Winching and Towing Procedures

This section provides the operator with procedures about towing and winching and on how to manually release the brakes.



WARNING

Ensure platform is fully lowered before winching or towing. Sudden motion could cause the aerial platform to become unstable. Death or serious injury could result.



WARNING

In emergency situations where aerial platform functions are not available and lowering is impeded by an obstacle, utmost care must be taken to move aerial platform far enough to clear the obstacle. In such cases, operation must be extremely smooth with no sudden movements and must not exceed a speed of 50 mm/sec.



WARNING

When pushing, winching or towing, do not exceed 3.2 km/h.



WARNING

Do not push, winch or tow aerial platform onto a slope, or brake the towing vehicle rapidly. Do not pull aerial platform down an incline towards a winch.

2.14-1 To Release Free-wheeling Valve

1. Ensure aerial platform is on level ground. Chock or block the wheels to keep aerial platform from rolling.

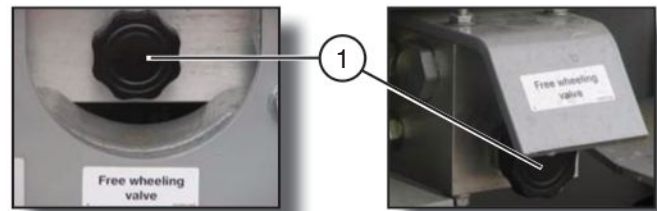

Figure 2-20. Free-wheeling Valve

2. **Free-wheeling Valve** - Turning valve knob counterclockwise (item 1) to a fully opened position allows fluid to flow through the wheel motors, thus providing “free-wheeling.”



WARNING

The free-wheeling valve must be closed tightly (clockwise) for normal operation.

2.14-2 To Release Brakes Manually

Releasing the brakes manually depends on the brake system that is provided on the aerial platform.



WARNING

Do not manually disengage brakes if the aerial platform is on a slope.

2.14-2a Pin Brakes System



Figure 2-21. Brakes



WARNING

Brakes must be manually disengaged for pushing, winching or towing.

1. Ensure aerial platform is on level ground. Chock or block wheels to keep aerial platform from rolling.
2. Turn main power disconnect switch to “○” off position.
3. **For Left-Side Brake:** Using a 19 mm wrench, rotate the block on the brake pin 90° clockwise. The brake pin should be clear of the brake disc.
4. **For Right-Side Brake:** Using a 19 mm wrench, rotate the block on the brake pin 90° counterclockwise. The brake pin should be clear of the brake disc.
5. Remove wheel chocks or blocks, then push, winch or tow aerial platform to desired location.

**WARNING**

Brakes must be reengaged immediately after reaching the desired location.

6. Position aerial platform on a firm and level surface.
7. Chock or block wheels to prevent aerial platform from rolling.
8. Reengage brakes by doing the following steps.
9. **For Left-Side Brake:** Using a 19 mm wrench, rotate the block on the brake pin 90° counterclockwise.
10. **For Right-Side Brake:** Using a 19 mm wrench, rotate the block on the brake pin 90° clockwise.
11. Close the free-wheeling valve.

2.14-2b Disc Brakes System

Figure 2-22. Brakes

**WARNING**

Brakes must be manually disengaged for pushing, winching or towing.

1. Ensure aerial platform is on level ground. Chock or block wheels to keep aerial platform from rolling.
2. Turn main power disconnect switch to “○” off position.
3. Locate the brake manifold at the rear of the base.
4. Push in brake auto reset valve plunger (item 1).
5. Grasp brake hand pump (item 2) and rapidly depress until firm resistance is felt. The brakes are now released.
6. Remove wheel chocks or blocks, then push, winch or tow aerial platform to desired location.

**WARNING**

Brakes must be reengaged immediately after reaching the desired location.

7. Position aerial platform on a firm and level surface.
8. Chock or block wheels to prevent aerial platform from rolling.
9. Reengage the brake by pulling out the brake auto reset valve plunger.
10. Close the free-wheeling valve.

2.15 Emergency Lowering Procedure

This section guides the operator on how to use the emergency lowering system. This system allows platform lowering in the event of an emergency or an electrical system failure.



WARNING

Keep clear of scissors mechanism when using emergency lowering valve.

1. Remove any obstructions from a lowering platform.
2. Extension platform(s) may need to be retracted or aerial platform may need to be moved to clear obstruction. Refer to Section 2.14 for winching and towing procedures.

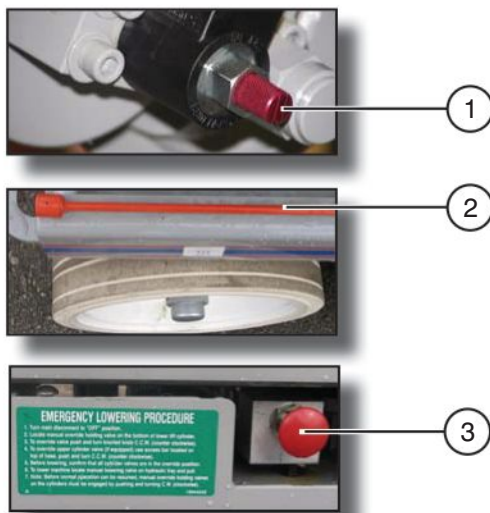

Figure 2-23. Emergency Lowering System

3. Locate the holding valve manual override knob (item 1) at the base of each lift cylinder. Depress and turn counterclockwise. If necessary, use emergency lowering access rod (item 2) that is located on aerial platform base.
4. On hydraulic/electric tray, pull out and hold emergency lowering valve (item 3) to lower platform.
5. To restore normal operation, depress and turn holding valve manual override knobs clockwise.

2.16 Maintenance Support Procedure

This section provides the operator with procedure regarding deployment and storage of maintenance support.

The maintenance support is a safety mechanism designed to support the scissor assembly. When properly positioned, it can support the scissor assembly and empty platform. The maintenance support must be used when inspection and/or maintenance is to be performed within the lifting mechanism.



WARNING

The maintenance support must be used when inspection and/or maintenance or repairs are to be performed within the lifting mechanism. Failure to use this safety mechanism could result in death or serious injury.

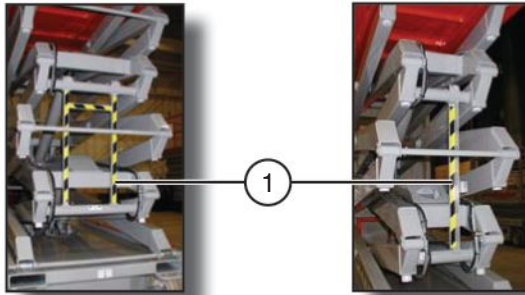

Figure 2-24. Maintenance Support

To Deploy the Maintenance Support

1. Remove all material from platform.
2. Raise platform until there is adequate clearance to swing down maintenance support (item 1).
3. Swing maintenance support down from storage bracket into a vertical position.
4. Remove hands and arms from scissors area.
5. Lower platform until bottom end of maintenance support contacts the labeled cross bar and scissors are supported by maintenance support.
6. Turn main power disconnect switch to “○” off position.

To Store the Maintenance Support

1. Turn main power disconnect switch to “I” on position.
2. Raise platform until there is adequate clearance to swing up the maintenance support.
3. Swing bar fully up into storage bracket.
4. Lower the platform.



WARNING

Do not reach through the scissor assembly when the platform is raised without the maintenance support properly positioned. Failure to avoid this hazard could result in death or serious injury.

2.17 Battery Maintenance

This section provides the operator with procedures on how to service and charge the battery. This also provides charger operation instructions.

2.17-1 Battery Service Procedures



WARNING

Explosion Hazard - Keep flames and sparks away. Do not smoke near batteries.



WARNING

Battery acid is extremely corrosive - Wear proper eye and facial protection as well as appropriate protective clothing. If contact occurs, immediately flush with cold water and seek medical attention.

1. Turn main power disconnect switch to “○” off position.
2. Check battery case for damage.
3. Check battery fluid level in each battery. If plates are not covered by at least 13 mm of solution, add distilled or demineralized water.
4. Clean battery terminals and cable ends thoroughly with a terminal cleaning tool or wire brush.
5. Make sure all battery connections are tight.
6. Replace any battery that is damaged or incapable of holding a lasting charge.
7. Do not use any batteries other than flooded lead-acid batteries of the proper AH rating.



WARNING

Use original or equivalent to the original parts and components for the aerial platform.

2.17-2 Battery Charging Operation

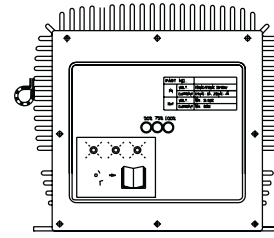

Figure 2-25. Battery Charger



DANGER

Risk of electric shock - Do not immerse the charger in water. Though the charger is highly resistant to water, it is not designed for immersion and an electric shock can occur.

1. Provide adequate ventilation for the batteries and charger. The convection cooled design requires access to cooling air for proper operation. Do not allow blankets or other materials to cover the charger. Although the charger protects itself against overheating, the charger cooling fins should be cleaned if clogged with debris for best performance.



WARNING

There could be a spark during charging. Be careful when using fuels, solvents or other flammables near the charger or batteries.

2. Connect the power supply cord to a properly grounded 100V/50 or 60Hz, 115V/50 or 60Hz, or 230V/50 or 60Hz socket. This charger automatically senses and adjusts to the AC input voltage range.



CAUTION

When changing the input voltage wait until all the LEDs are OFF or wait a minimum of 20 seconds before switching on the new voltage.

- The charging time is affected by numerous factors including battery Amp-Hour capacity, depth of discharge, battery temperature, and battery condition (new, old or defective). Batteries larger than 240 AH can be recharged but will take longer.



WARNING

Do not disconnect the DC output wires near the batteries when the charger is ON. The resulting arcing could cause the batteries to explode. If the charger must be disconnected, first disconnect the AC power supply cord from its outlet, then disconnect the charger DC connections.



WARNING

Risk of an electric shock - Do not touch un-insulated parts of the charger output wires, battery connector, or battery terminals.



WARNING

Visually and manually inspect to verify the DC output wires and terminals are in good working condition before each use.

- The charger will start automatically within four to six seconds. The charger will start even with severely discharged batteries (down to 1V terminal voltage). Once charging starts, the LEDs indicate the charging progress.

Charging State LED

State of charge	1 ST LED	2 ND LED	3 RD LED
0 to 50%	Blinking	Off	Off
50% to 75%	On	Blinking	Off
75% to 100%	On	On	Blinking
100%	On	On	On

60133AA

The charger goes into an equalizing charge mode after the batteries are charged and all 3 LEDs are “ON”. The charger will continue to charge at a low current then shut off automatically when complete. If all 3 LEDs blink together, there is a problem.

Take proper action according to the following instructions:

3 LEDs blink once simultaneously:

Output connection error. Check the battery and charger connection. The output may not be connected to the batteries or the connections to the batteries may have corroded or loosened. The output may be shorted due to improper connection to the batteries or pinched wires. The output may be connected in reverse polarity to the batteries. The charger is not damaged by any of these problems.

3 LEDs blink twice simultaneously:

The charger is indicating that the AC voltage is too low or too high. Check the AC input voltage.

3 LEDs blink three times simultaneously:

Charger is overheated. No action required. When the charger cools, charging will restart automatically. Check and correct for dirt or other debris on charger that may be reducing cooling.

3 LEDs blink four times simultaneously:

Input or output over current. No action required, charger will correct and restart automatically.

100% LED lamp blinks:

Charger 18 hour timer has timed out due to battery problem.

Batteries do not fully charge.

If the batteries are charged overnight, make sure the AC supply is not being switched off at night with other building items. Check battery condition and for dead cells or reduced capacity. Replace charger only if other problems are not found.

The AC line circuit breaker or fuse is blown.

A defective circuit breaker or fuse, an overloaded circuit, or a charger problem can cause this condition. Try connecting the charger to a different AC outlet (on a different circuit) in the building. If the AC supply checks good, the charger should be replaced.

EE-Rated Aerial Platforms**WARNING**

**Do not charge batteries in hazardous area!
The EE-rating of a aerial platform does not
include the charging of batteries.**

1. Move the aerial platform to an area designated for battery charging. Refer to NFPA 505 for charging setup. NFPA 505 is a publication of the **National Fire Protection Association, Inc.**, Batterymarch Park, Quincy, MA 02269 (USA).
2. Connect battery charger DC plug into the battery tray.
3. Charge batteries. Refer to Section 2.17-2 for battery charging operation. When charge cycle is completed, disconnect charger plug from battery tray.

Table 2.1 Standard and Optional Features - CE

Models	Compacts		Conventionals						
	3215	3219	3220	3226	4620	4626	4632	6826	6832
STANDARD EQUIPMENT									
Drivable at full height	*	*	*	*	*	*	to 8m	*	to 8m
Dual parking brakes	*	*	*	*	*	*	*	*	*
Universal battery charger	*	*	*	*	*	*	*	*	*
Color coded and numbered wiring system	*	*	*	*	*	*	*	*	*
.9m Roll out deck extension	*	*	*	*	*	*	*	*	*
Swing out trays for easy access	*	*	*	*	*	*	*	*	*
Joystick proportional control for drive/lift	*	*	*	*	*	*	*	*	*
Tilt alarm with drive/lift cut out	*	*	*	*	*	*	*	*	*
Wiring for AC outlet	*	*	*	*	*	*	*	*	*
Lanyard attachments anchors	*	*	*	*	*	*	*	*	*
Rigid steel scissor guards								*	*
Hinged railing system				*		*	*	*	*
Lowering warning system	*	*	*	*	*	*	*		
Overload sensing system	*	*	*	*	*	*	*	*	*
Forklift pockets/tie downs/lifting lugs	*	*	*	*	*	*	*	*	*
Pothole protection	*	*	*	*	*	*	*		
Operator horn	*	*	*	*	*	*	*	*	*
DC power (V DC)	24	24	24	24	24	24	24	24	24
Base control console	*	*	*	*	*	*	*	*	*
Spring loaded half height gate	*	*	*	*	*	*	*	*	*
OPTIONAL EQUIPMENT									
Spring loaded full gate entry	*	*	*	*	*	*	*	*	*
1.8m Powered extension platform			*		*	*	*		
1.5m Powered extension platform								*	*
Flashing light	*	*	*	*	*	*	*	*	*
Hinged railing system	*	*	*		*				
Shop air line to platform	*	*	*	*	*	*	*	*	*
Non-marking foam filled tires								*	*
All motion alarm	*	*	*	*	*	*	*	*	*

60381AD-CE

Table 2.2 Owner's Annual Inspection Record

Model Number: _____		Serial Number: _____							
Recording Date									
Recording Year #	1	2	3	4	5	6	7	8	9
Owner's Name									
Inspected By									

60141AB

As described earlier in this section, this decal is located on the scissor assembly. It must be completed after an annual inspection has been completed. Do not use the aerial platform if an inspection has not been recorded in the last 13 months.

Table 2.3a Specifications and Features

MODEL	3215	3219	3220	3226
Weight *	1090 kg	1170 kg	1542 kg	1896 kg
Width	0.81 m		0.81 m	
Length	1.78 m		2.3 m	
Platform Size	0.66 x 1.63 m		0.71 x 2.1 m	
Height				
Working Height	6.4 m	7.6 m	8.1 m	9.9 m
Platform Elevated Height	4.6 m	5.8 m	6.1 m	7.9 m
Stowed Platform Height	0.88 m	0.99 m	0.97 m	1.1 m
Stowed Height Railings Up	1.88 m	1.99 m	2.1 m	2.3 m
Drive Height (All Standards)	FULL			
Standard Operating Time				
Lift Time (No Load)	18 sec.	20 sec.	27 sec.	47 sec.
Lower Time (No Load)	32 sec.	39 sec.	41 sec.	63 sec.
Lift Time (Rated Load)	23 sec.	25 sec.	33 sec.	51 sec.
Lower Time (Rated Load)	24 sec.	29 sec.	29 sec.	46 sec.
Chassis				
Normal Drive Speed	3.2 km/h		3.0 km/h	3.8 km/h
Elevated Drive Speed	1.05 km/h		1.0 km/h	1.0 km/h
High Torque Drive Speed	N/A		1.5 km/h	1.9 km/h
Gradeability	23%		25%	
Tires (Solid Rubber)	12 x 4 x 8		16 x 5 x 12	

60156AL-CE-1-R

* Weight with standard 0.9 m extension platform.
(Refer to nameplate for aerial platforms with 1.5 m or 1.8 m extension platform.)

Table 2.3b Specifications and Features

MODEL	4620	4626	4632	6826	6832
Weight †	1860 kg	2130 kg	2300 kg	2440 kg	2700 kg
Width	1.17 m			1.73 m	
Length	2.31 m			2.52 m	
Platform Size	1.07 x 2.11 m			1.53 x 2.05 m	
Height					
Working Height	7.92 m	9.75 m	11.6 m	9.75 m	11.6 m
Platform Elevated Height	6.1 m	7.9 m	9.7 m	7.9 m	9.7 m
Stowed Platform Height	0.97 m	1.14 m	1.23 m	1.27 m	1.40 m
Stowed Height Railings Up	1.96 m	2.15 m	2.24 m	2.37 m	2.51 m
Drive Height	6.1 m	7.9 m	9.7 m	7.0 m	7.9 m
Standard Operating Time					
Lift Time (No Load)	24 sec.	48 sec.	50 sec.	N/A	58 sec.
Lower Time (No Load)	48 sec.	45 sec.	62 sec.	N/A	63 sec.
Lift Time (Rated Load)	32 sec.	54 sec.	59 sec.	65 sec.	60 sec.
Lower Time (Rated Load)	32 sec.	32 sec.	49 sec.	57 sec.	51 sec.
Chassis					
Normal Drive Speed	3.2 km/h				
Elevated Drive Speed	0.90 km/h				0.74 km/h
High Torque Drive Speed	1.6 km/h				
Gradeability	25%				
Tires	16 x 5 x 12 Solid Rubber			23 x 10.5 x 12 Foam Filled ¹	

60156AL-CE-2-R

† Weight with standard 0.9m extension platform. Refer to serial nameplate for specific applications.

¹ Fill hardness: 55 Durometer

Table 2.4 Floor Loading Pressure

MODEL		Total Aerial Platform Weight	Total Aerial Platform Load		
			Wheel	LCP**	OUP**
		kg	kg	KPa (kN/m ²)	KPa (kN/m ²)
3215	min*	1089	435	689.5	7.5
	max*	1361	544	758.5	9.5
3219	min*	1170	468	689.5	8.0
	max*	1420	568	758.5	10.0
3220	min*	1542	616	758.5	8.5
	max*	1950	780	896.5	11.5
3226	min*	1896	746	827.5	10.0
	max*	2091	836	896.5	11.5
4620	min*	1860	744	1316.9	7.0
	max*	2549	1021	1530.6	9.5
4626	min*	2132	853	1420.3	8.0
	max*	2685	1075	1544.4	10.1
4632	min*	2302	921	1434.1	8.6
	max*	2620	1048	1537.5	9.8
6826	min*	2368	947	538.0	5.5
	max*	2912	1165	579.0	6.5
6832	min*	2663	1065	565.5	6.0
	max*	3207	1283	648.0	7.5

60354AG-CE-R

* **min** - Total aerial platform weight with no options

max - Aerial platform weight + all options + full capacity

** **LCP - Locally Concentrated Pressure** is a measure of how hard the aerial platform presses on the areas in direct contact with the floor. The floor covering (tile, carpet, etc.) must be able to withstand more than the indicated values above.

OUP - Overall Uniform Pressure is a measure of the average load the aerial platform imparts on the whole surface directly underneath it. The structure of the operating surface (beams, etc.) must be able to withstand more than the indicated values above.

NOTE:

The **LCP** or **OUP** that an individual surface can withstand varies from structure to structure and is generally determined by the engineer or architect for that particular structure.

Floor Loading Pressure

Locally Concentrated Pressure (LCP):

Foot Print Area = Length x Width

$$LCP = \frac{\text{Weight of Aerial Platform} + \text{Capacity}}{\text{Foot Print Area} \times 4 \text{ (Tires)}}$$

Overall Uniform Pressure (OUP):

Base Area = Length x Width

$$OUP = \frac{\text{Weight of Aerial Platform} + \text{Capacity}}{\text{Base Area}}$$

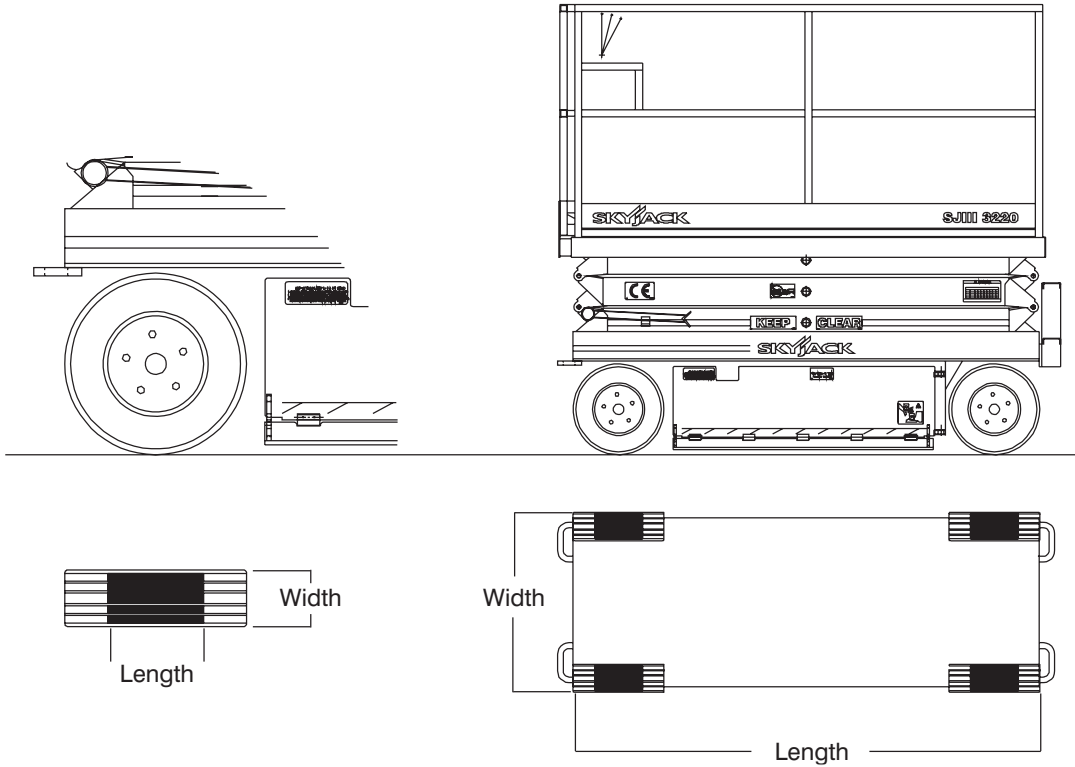

! WARNING

Intermixing tires of different types or using tires of types other than those originally supplied with this equipment can adversely affect stability. Therefore, replace tires only with the exact original Skyjack-approved type. Failure to operate with matched approved tires in good condition may result in death or serious injury.

Table 2.5 Maximum Platform Capacities (Evenly Distributed)

MODEL	Manual Extension Platform				Powered Extension Platform				Maximum Wind Speed	Tilt Cutout Setting
	Total Capacity		Extension Capacity		Total Capacity		Extension Capacity			
3215	227 kg	2 Persons	113 kg	1 Person	N/A				No Wind	1.5 x 3.5
3219	227 kg	2 Persons	113 kg	1 Person	N/A				No Wind	1.5 x 3.5
3220	408 kg 2 Persons				363 kg 2 Persons				No Wind	1.5 x 3.5
3226	227 kg 2 Persons				N/A				No Wind	1.5 x 3.5
4620	590 kg	3 Persons	136 kg	1 Person	590 kg	3 Persons	136 kg	1 Person	12.5 m/s	1.5 x 3.5
4626	454 kg	3 Persons	136 kg	1 Person	454 kg	3 Persons	136 kg	1 Person	12.5 m/s	1.5 x 3.5
4632	317 kg	2 Persons	113 kg	1 Person	N/A				10.8 m/s	1.5 x 3.5
6826	454 kg	3 Persons	136 kg	1 Person	N/A				12.5 m/s	2 x 4
6832	454 kg	3 Persons	136 kg	1 Person	N/A				12.5 m/s	2 x 4

60315AJ-CE-R

NOTE: Overall Capacity - Occupants and materials not to exceed rated load.

BEAUFORT SCALE	Wind Speed				Ground Conditions
	m/s	km/h	ft/s	mph	
3	3.4 – 5.4	12.5 – 19.4	11.5 – 17.75	5 – 12.0	Papers and thin branches move, flags wave
4	5.4 – 8.0	19.4 – 28.8	17.75 – 26.25	12.0 – 18	Dust is raised, paper whirls up, and small branches sway.
5	8.0 – 10.8	28.8 – 38.9	26.25 – 35.5	18 – 24.25	Shrubs with leaves start swaying. Wave crests are apparent in ponds or swamps.
6	10.8 – 13.9	38.9 – 50.0	35.5 – 45.5	24.5 – 31	Tree branches move. Power lines whistle. It is difficult to open an umbrella.
7	13.9 – 17.2	50.0 – 61.9	45.5 – 65.5	31 – 38.5	Whole trees sway. It is difficult to walk against the wind.

60338AC



WARNING

This aerial platform is equipped with a load sensing system. Do not exceed the rated capacity of the aerial platform. Failure to avoid this will prevent operation of all normal controls/functions of the aerial platform. To resume normal operation remove the additional loads.

Table 2.6 EC Declaration of Conformity

EC Declaration of Conformity

We, SKYJACK INC., [*], declare under our sole responsibility that the product Scissor Type Elevating Work Platform

Model number: [*]

Serial number: [*]

To which this declaration relates is in conformity with the following directives:

Machinery Directive 98/37/EC

Notified body is: [*]

EC type Examination Certificate No: [*]

Machinery Directive 98/37/EC as related to Load Sensing System

Notified body is: [*]

EEC Type Examination Certificate No: [*]

Directive 89/336/EEC

Certified laboratory: [*]

The Technical Construction File is maintained at:

[*]

The authorized representative located within the community is:

[*]

Place of issue:

[*]

Note: In case of unauthorized modification, this Declaration becomes invalid.

Test Engineer:

Quality Coordinator:

[*] For information refer to the English Declaration of Conformity provided with your aerial platform.

General Maintenance

Before attempting any repair work, disconnect the battery by turning the main power disconnect switch to “○” off position. Preventive maintenance is the easiest and least expensive type of maintenance.

Table 2.7 Maintenance and Inspection Schedule

Frequency	Daily	3 months or 150 hours	Yearly	Frequency	Daily	3 months or 150 hours	Yearly
Visual and Daily Maintenance Inspections				Lifting Mechanism			
Labels	A			Maintenance Support	A		B*
Electrical	A			Scissor Assembly	A		
Limit Switches	A			Scissor Bumpers	A		
Hydraulic	A			Rollers	A		
Entrance Side				Lift Cylinder(s)	A		
Main Power Disconnect Switch	A			Function Tests			
Base Control Switches	A			Test Main Power Disconnect Switch	A		B*
Free-wheeling Valve Knob	A			Base Control Console			
Brakes	A			Test Base Emergency Stop	A		
220V Outlet Receptacle	A			Test Off/Platform/Base Switch	A		
Ladder	A			Test Lower/Neutral/Raise Switch	A		
Battery Tray Side				Test Emergency Lowering	A		
Pothole Protection Device	A		B*	Test Free-wheeling	A		
Battery Tray	A			Platform Control Console			
Battery Charger	A			Test Platform Emergency Stop	A		
Battery	A			Test Enable Trigger Switch	A		
Steer Cylinder Assembly	A			Test Steering	A		
Wheel/Tire Assembly	A			Test Driving	A		
Tie Rod (Conventionals)	A			Test Brakes	A		
Greasing Points	A			Test Platform Raising/Lowering	A		
Hydraulic/Electric Tray Side				Test Lowering Warning	A		
Pothole Protection Device	A			Test Pothole Sensor	A		
Hydraulic Tank	A			Test Horn	A		
Hydraulic Oil	A			Test Speed Limit	A		
Hydraulic Pump and Motor	A						
Electrical Panel	A						
Proportional and Main Manifolds	A						
Load/Tilt Sensor	A						
Emergency Lowering Access Rod (If Equipped)	A						
Platform Assembly	A						
Lanyard Attachment Anchors	A						
AC Outlet on Platform	A						
Platform Control Console	A						
Manuals	A						
Powered Extension Control Console (If Equipped)	A						

60598AB-CE

A - Perform Visual and Daily Maintenance Inspections & Functions Test. Refer to [Section 2.8](#) and [Section 2.9](#) of this manual.

B - Perform Scheduled Maintenance Inspection. Refer to Service & Maintenance manual.

* - Maintenance must be performed only by trained and competent personnel who are familiar with mechanical procedures.



WARNING

Use original or equivalent to the original parts and components for the aerial platform.

Table 2.8 Operator's Checklist



Serial Number: _____
 Model: _____
 Hourmeter Reading: _____
 Date: _____
 Time: _____

Operator's Name (Printed): _____
 Operator's Signature: _____

Each item shall be inspected using the the appropriate section of the Skyjack operating manual.
 As each item is inspected, check the appropriate box.

- P** - PASS
- F** - FAIL
- R** - REPAIRED
- NA** - NOT APPLICABLE

INSPECTION FREQUENCY

- FREQUENTLY
- DAILY
- ANNUALLY
- BI-ANNUALLY

	N/A	P	F	R
Visual and Daily Maintenance Inspections				
Labels				
Electrical				
Limit Switches				
Hydraulic				
Entrance Side				
Main Power Disconnect Switch				
Base Control Switches				
Free-wheeling Valve Knob				
Brakes				
220V Outlet Receptacle				
Ladder				
Battery Tray Side				
Pothole Protection Device				
Battery Tray				
Battery Charger				
Battery				
Steer Cylinder Assembly				
Wheel/Tire Assembly				
Tie Rod (Conventionals)				
Greasing Points				
Hydraulic/Electric Side				
Pothole Protection Device				
Hydraulic Tank				
Hydraulic Oil				
Hydraulic Pump and Motor				
Electrical Panel				
Proportional and Main Manifolds				
Load/Tilt Sensor				
Emergency Lowering Access Rod (If Equipped)				
Platform Assembly				
Lanyard Attachment Anchors				
AC Outlet on Platform				
Platform Control Console				
Manuals				
Powered Extension Control Console (If Equipped)				

	N/A	P	F	R
Lifting Mechanism				
Maintenance Support				
Scissor Assembly				
Scissor Bumpers				
Rollers				
Lift Cylinder(s)				
Function Tests				
Test Main Power Disconnect Switch				
Base Control Console				
Test Base Emergency Stop				
Test Off/Platform/Base Switch				
Test Lower/Neutral/Raise Switch				
Test Emergency Lowering				
Test Free-wheeling				
Platform Control Console				
Test Platform Emergency Stop				
Test Enable Trigger Switch				
Test Steering				
Test Driving				
Test Brakes				
Test Platform Raising/Lowering				
Test Lowering Warning				
Test Pothole Sensor				
Test Horn				
Test Speed Limit				

60600AB-CE

Note:
 Make a copy of this page or visit the Skyjack web site:
www.skyjack.com for a printable copy.

Labels and Nameplates - Models 3215 & 3219

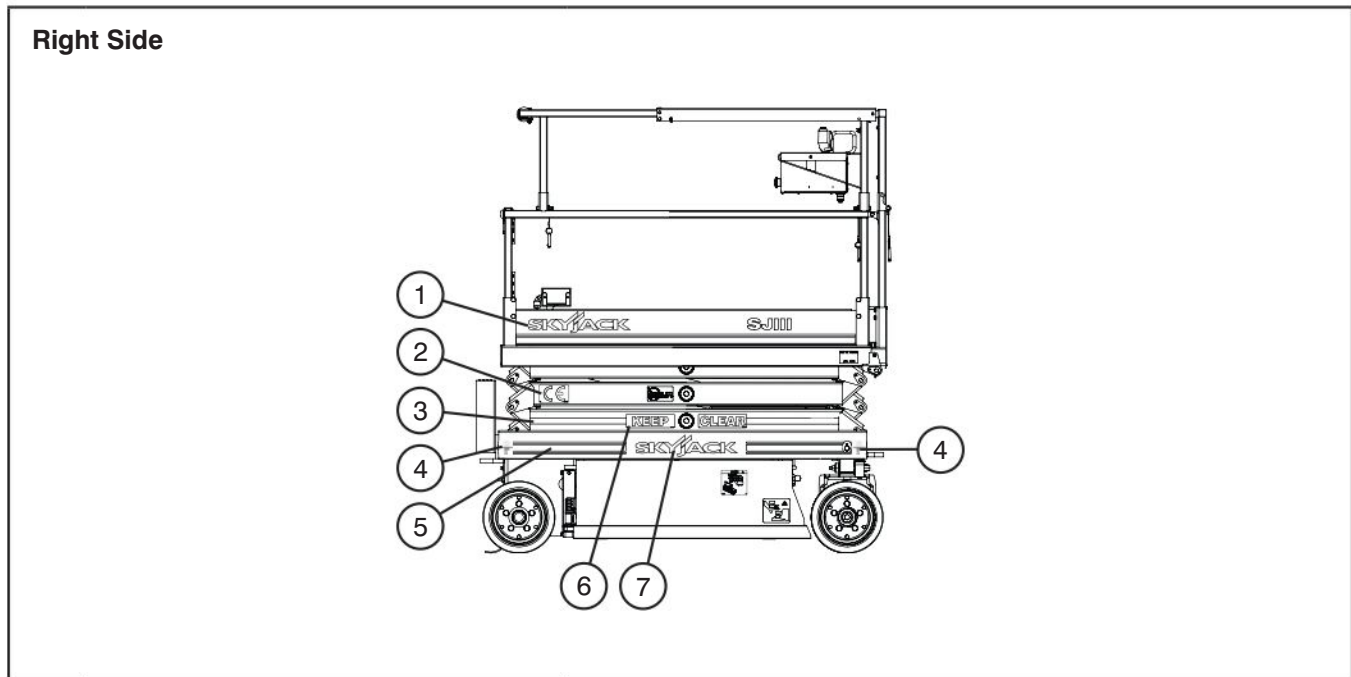

No.	Label Pictorial	Description
1		Skyjack Logo Small Skyjack logo - blue
2		“CE” CE rating mark
3		Caution Tape Stripe Caution stripe
4		Wheel Load 570 kg/1260 lb. Indicates rated wheel load.
5		Tape - Red/Blue/Red Skyjack pinstripe
6		“Keep” Keep clear.
7		Skyjack Logo Small Skyjack logo - blue and red

Labels and Nameplates - Models 3215 & 3219

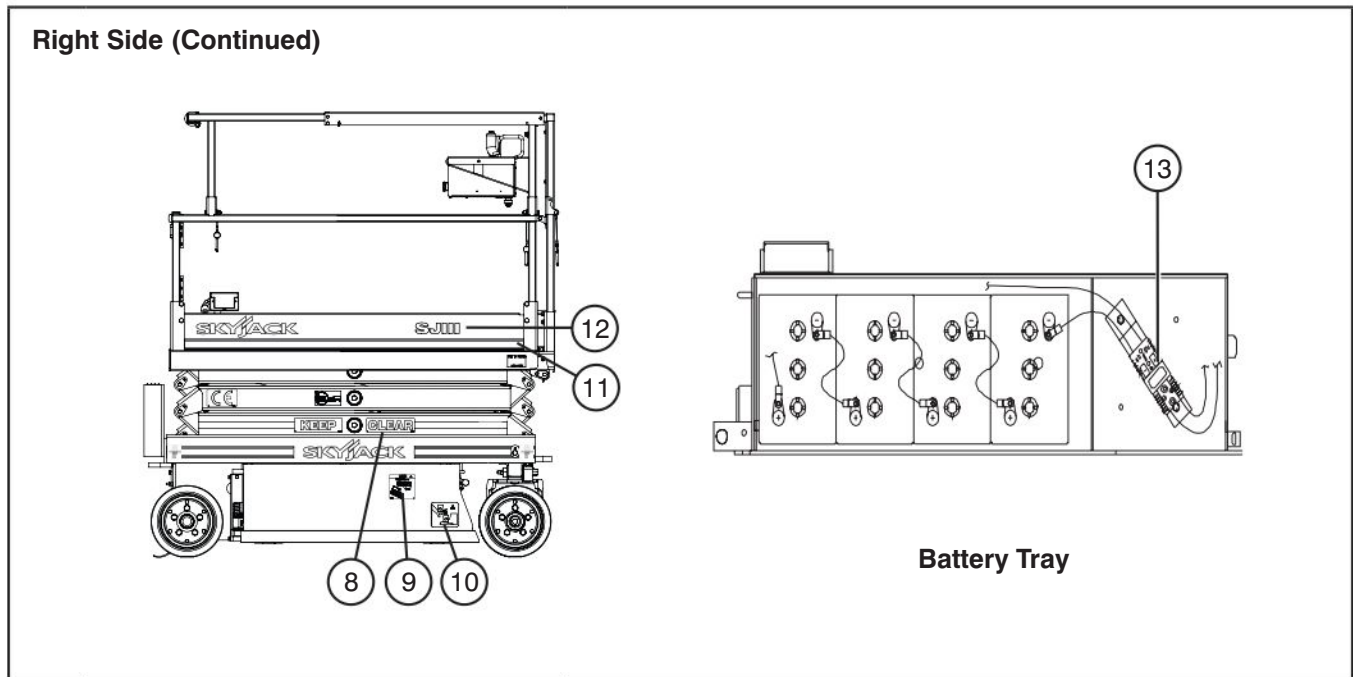

No.	Label Pictorial	Description
8		“Clear” Keep clear.
9		Battery Spacers* Place spacers only as shown in diagram. *Spacers vary over different units.
10		Crushing Hazard Danger - Crushing hazard
11		Tape Blue/White Skyjack pinstripe
12		Model Number* Product Identifier *Model number will vary, may not be as shown.
13		Battery - Charger Connection Connect charger to batteries at this point.



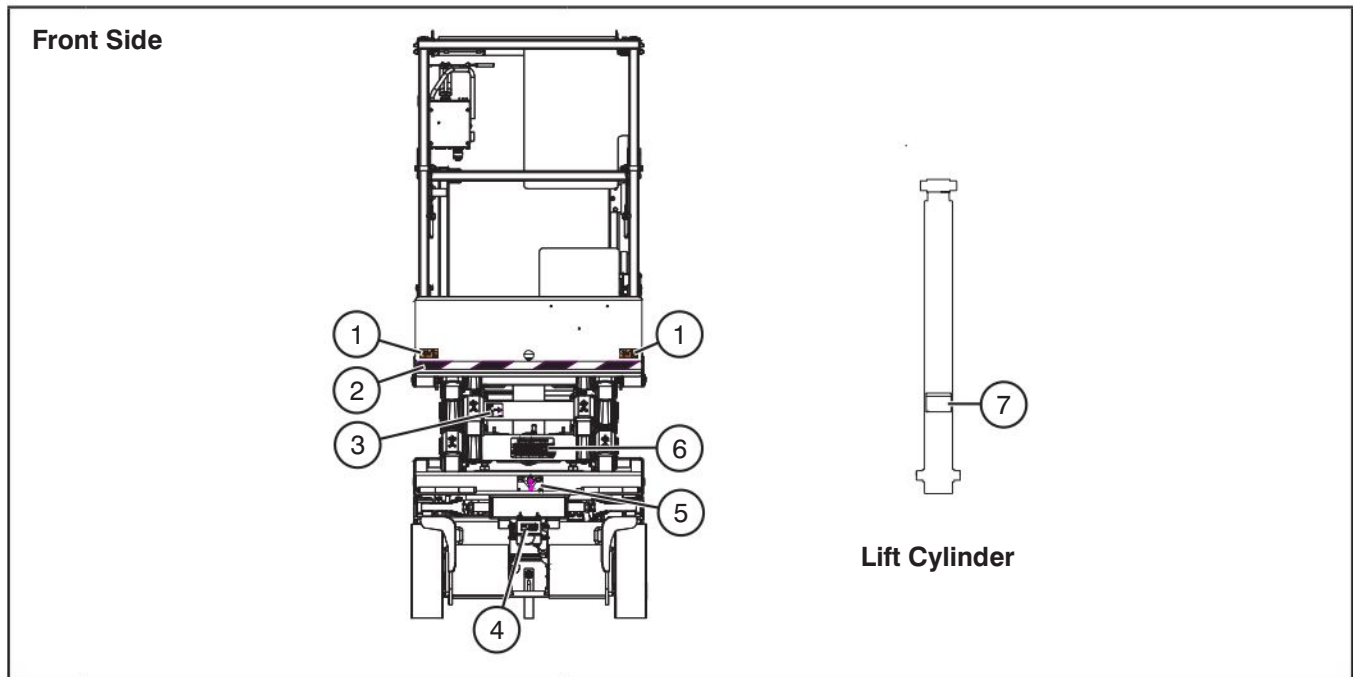



Labels and Nameplates - Models 3215 & 3219

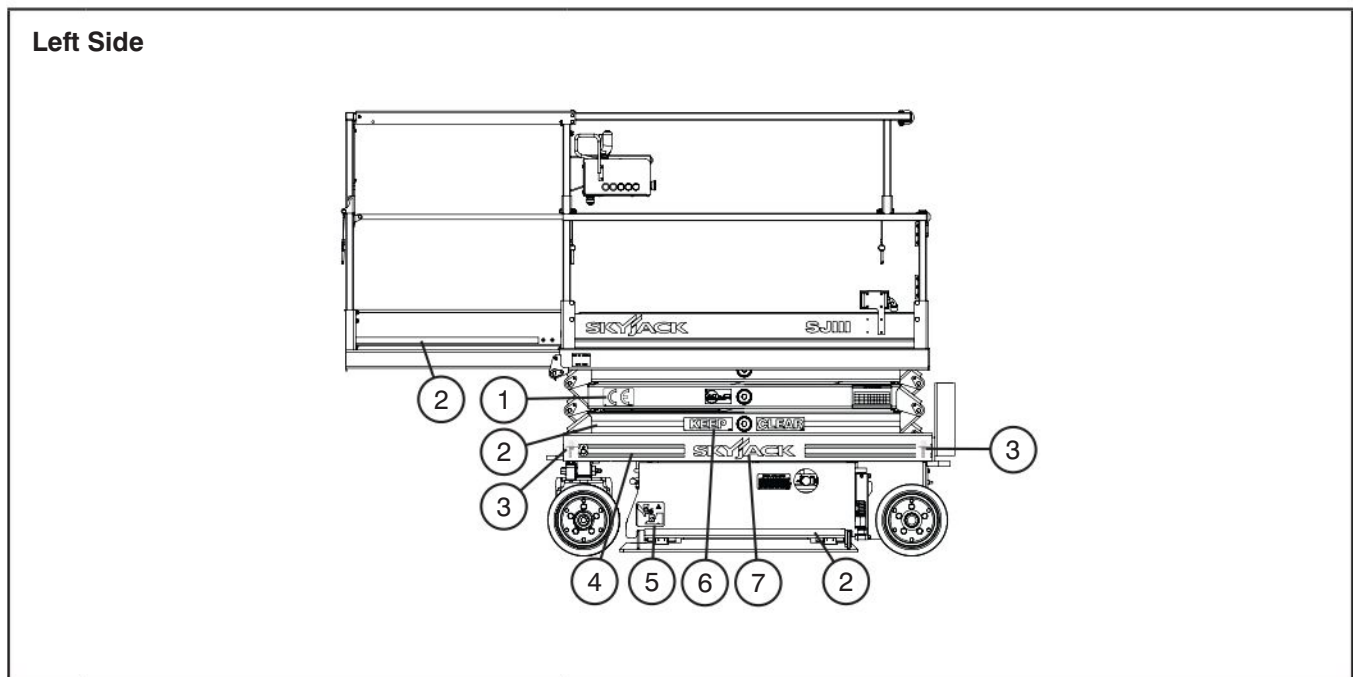

No.	Label Pictorial	Description
1		Crushing Hazard Danger - Crushing hazard
2		Caution Tape Stripe Caution stripe
3		Maintenance Support Deploy maintenance support here.
4		Free-wheeling Valve Open valve to initiate free wheeling prior to winching/towing/pushing.
5		Lift and Tie Down Points Only use these points for lifting or tying down.
6		Emergency Lowering Procedure In case of emergency, follow procedure outlined in label to lower the platform.
7		Orifice Installed Orifice installation warning

Labels and Nameplates - Models 3215 & 3219



No.	Label Pictorial	Description
1		“CE” CE rating mark
2		Caution Tape Stripe Caution stripe
3		Wheel Load 570 kg/1260 lb. Indicates rated wheel load.
4		Tape - Red/Blue/Red Skyjack pinstripe
5		Crushing Hazard Danger - Crushing hazard
6		“Keep” Keep clear.
7		Skyjack Logo Small Skyjack logo - blue and red

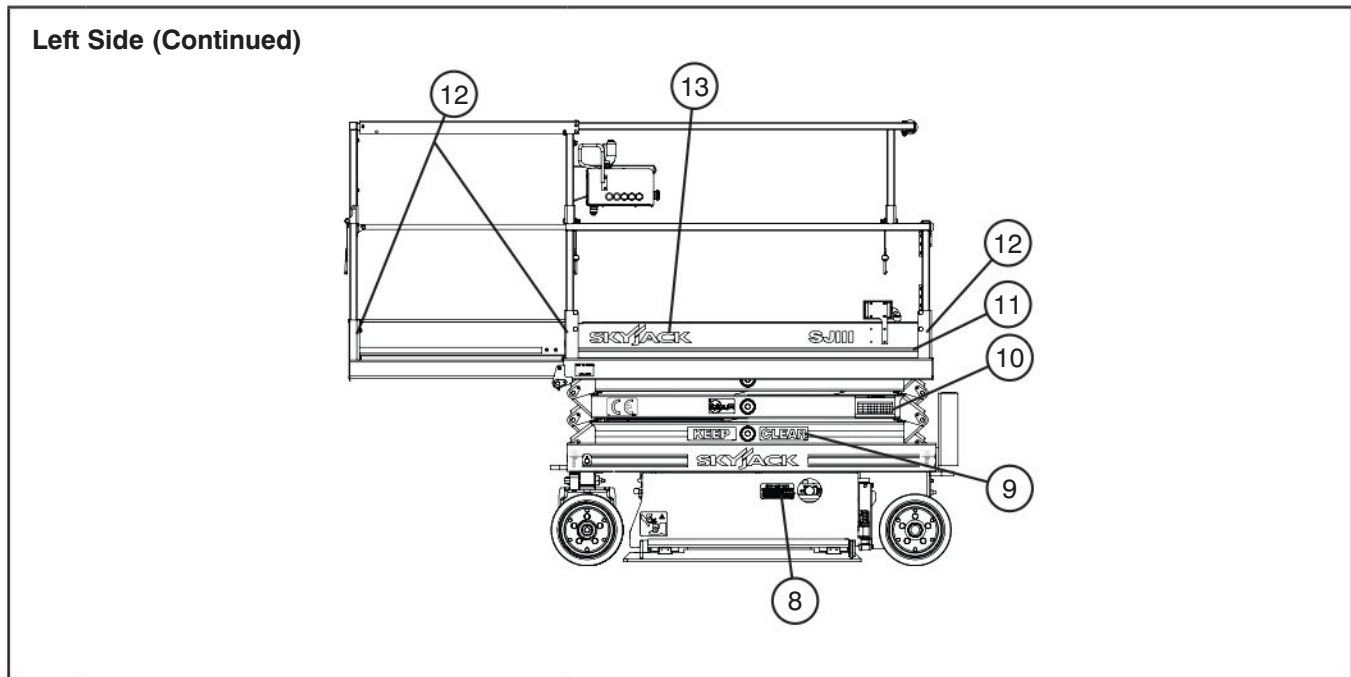

Labels and Nameplates - Models 3215 & 3219

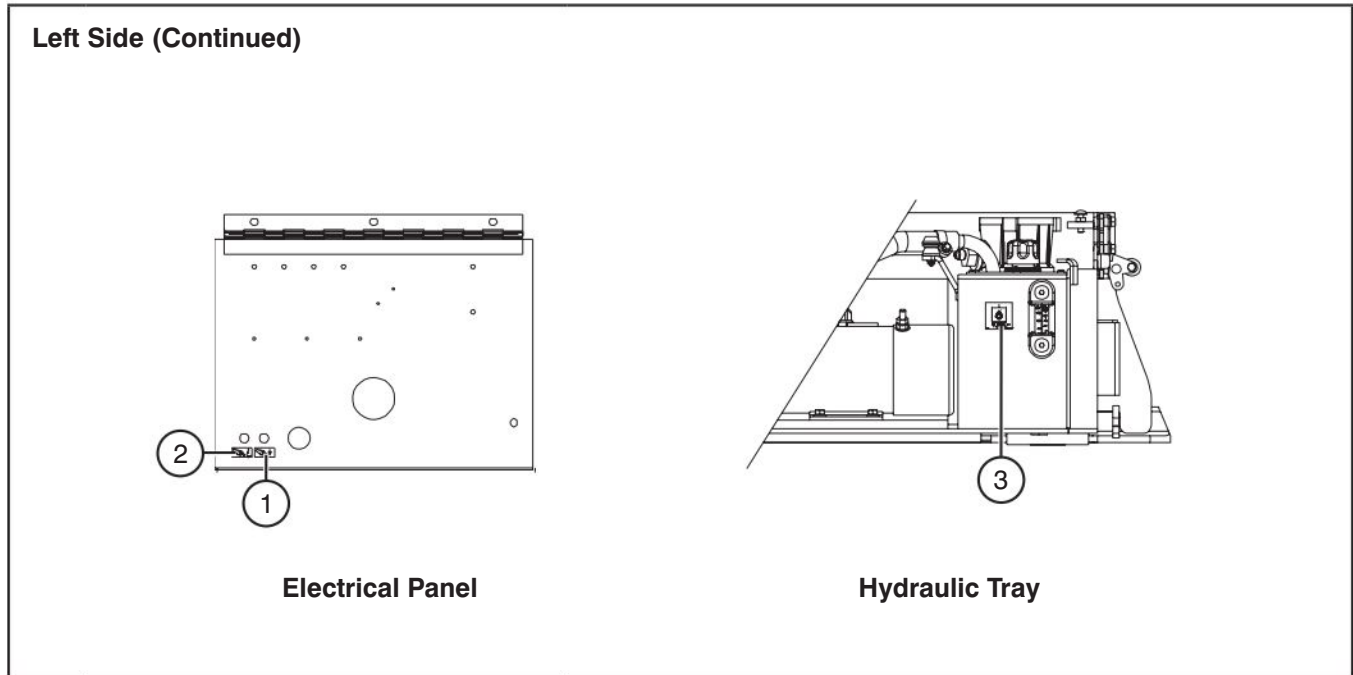

No.	Label Pictorial	Description
8		<p>Emergency Lowering Procedure</p> <p>In case of emergency, follow procedure outlined in label to lower the platform.</p>
9		<p>“Clear”</p> <p>Keep clear.</p>
10		<p>Annual Inspection</p> <p>Ensure that work platform has received annual inspection prior to operation.</p>
11		<p>Tape Blue/White</p> <p>Skyjack pinstripe</p>
12		<p>Lanyard Anchorage Point</p> <p>Attach anchorage harness lanyard here.</p>
13		<p>Skyjack Logo</p> <p>Small Skyjack logo - blue</p>

Labels and Nameplates - Models 3215 & 3219

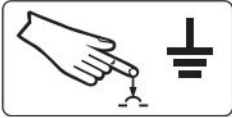

No.	Label Pictorial	Description
1		<p>Ground Circuit Breaker</p> <p>Push to reset ground circuit breaker.</p>
2		<p>Power Circuit Breaker</p> <p>Push to reset power circuit breaker.</p>
3		<p>Hydraulic Oil ATF Dexron III</p> <p>Replace hydraulic fluid with ATF Dexron III only.</p>

Labels and Nameplates - Models 3215 & 3219

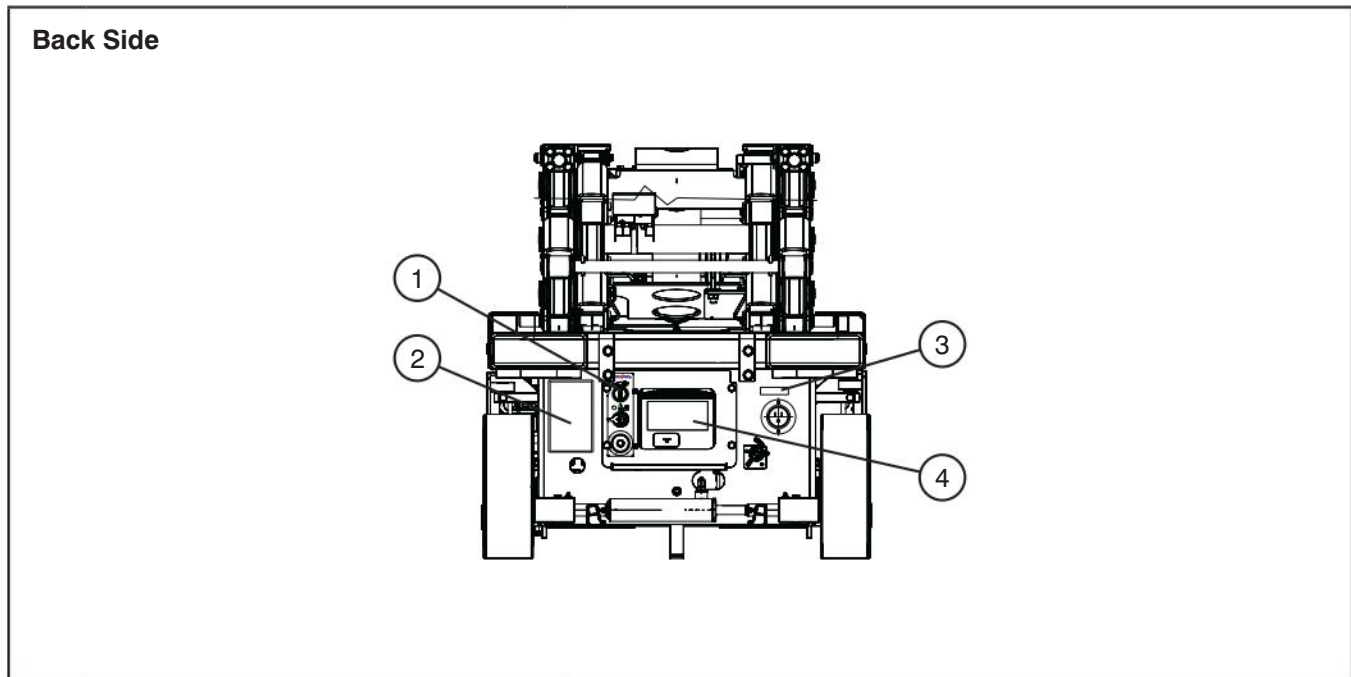

No.	Label Pictorial	Description
1		<p>Base Control Console</p> <p>Select “ ” to lower or “ ” raise platform.</p> <p>Select “ ” platform to enable platform controls, “ ” off to disable controls or “ ” base to enable base control console.</p> <p>Push “ ” to disable controls.</p>
2		<p>Serial Plate*</p> <p>Product identification and specifications *Serial plates will vary, may not be as shown.</p>
3		<p>Connect Platform AC Supply</p> <p>Connect AC power supply here for platform accessory outlet.</p>
4		<p>Charger Information (24V)</p> <p>Charger specification information and operation status; consult manual.</p>

Labels and Nameplates - Models 3215 & 3219

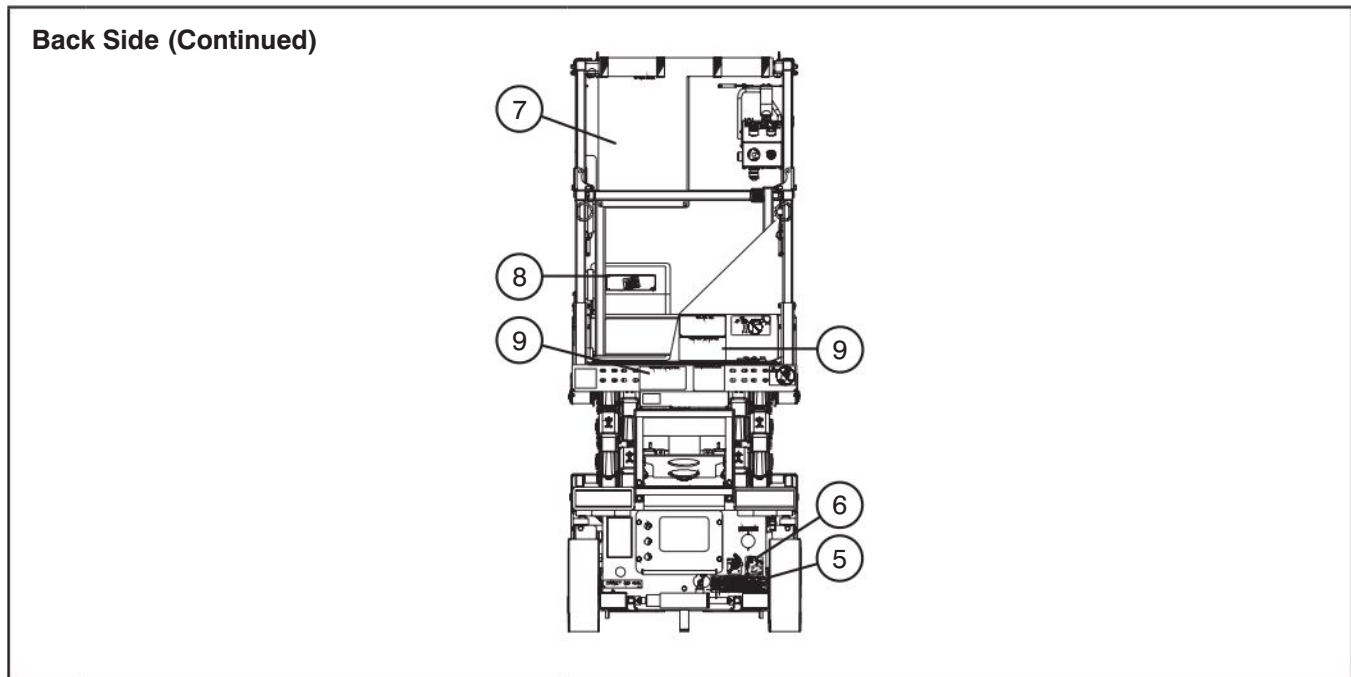

No.	Label Pictorial	Description
5		<p>Winching/Towing/Pushing Procedure</p> <p>Winching/towing/pushing procedure. Ensure brake is released and free-wheeling valve is open before moving the unit manually.</p>
6		<p>Main Power Disconnect</p> <p>Rotate clockwise to turn on main power; rotate counterclockwise to turn off main power; insert padlock to lock in position.</p>
7		<p>Hazard Identification</p> <p>Read and understand the outlined risks associated with this work platform prior to operation.</p>
8		<p>Manual Storage Box</p> <p>Indicates location of operating manual.</p>
9		<p>Platform Capacity*</p> <p>Rated work load in each configuration is as shown. Rated work load includes the weight of both personnel and material. Maximum number of people in each configuration is as shown. Do not exceed total weight or maximum number of people. Load platform uniformly.</p> <p>*Platform capacity varies over different aerial platforms.</p>

Labels and Nameplates - Models 3215 & 3219

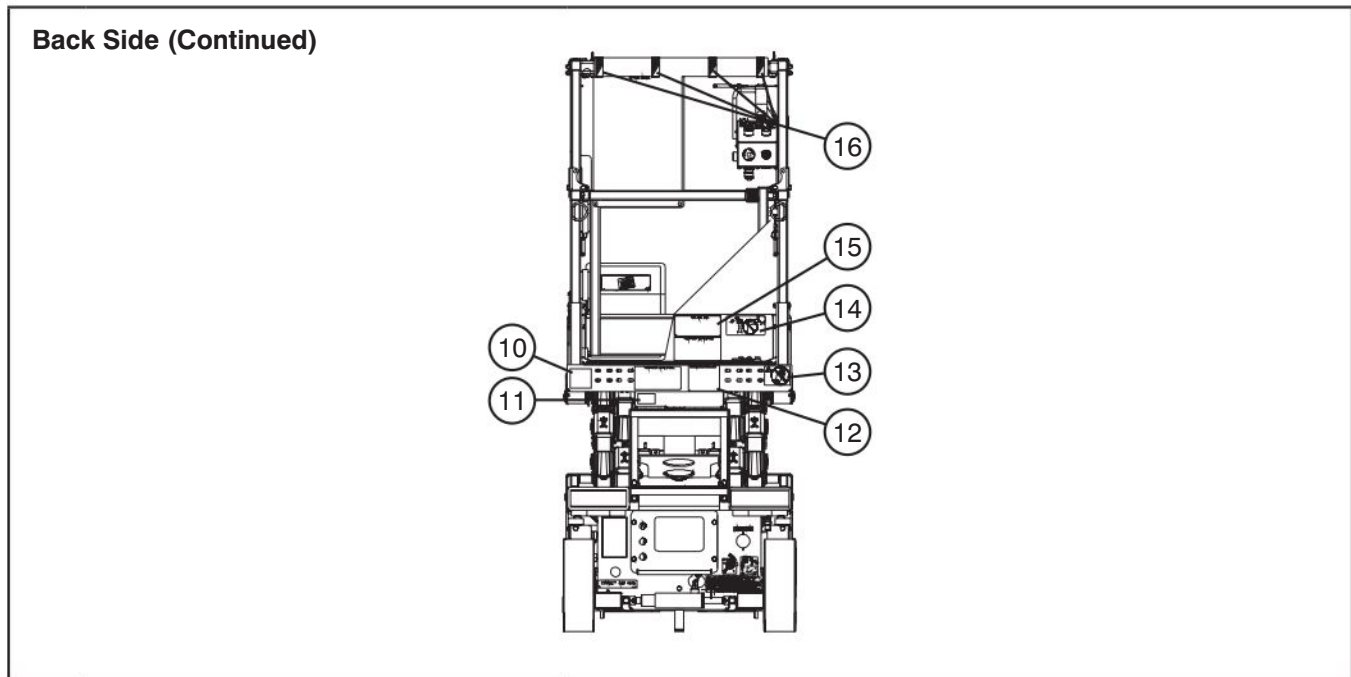

No.	Label Pictorial	Description
10		<p>Inverter Switch</p> <p>Turn inverter switch to off position after use.</p>
11		<p>Warning - Do Not Alter</p> <p>Aerial platform altering warning</p>
12		<p>Operator Checklist</p> <p>Operator checklist. Perform check prior to use.</p>
13		<p>No Jewelry</p> <p>Caution - Do not wear jewelry.</p>
14		<p>Horizontal Load Rating*</p> <p>Apply no more than the indicated side load. Operate below indicated wind speed only. *Horizontal load rating will vary, may not be as shown.</p>
15		<p>Standards Compliance</p> <p>Indicates standards to which the work platform complies.</p>
16		<p>Caution Tape Stripe</p> <p>Caution stripe</p>

Labels and Nameplates - Models 3215 & 3219

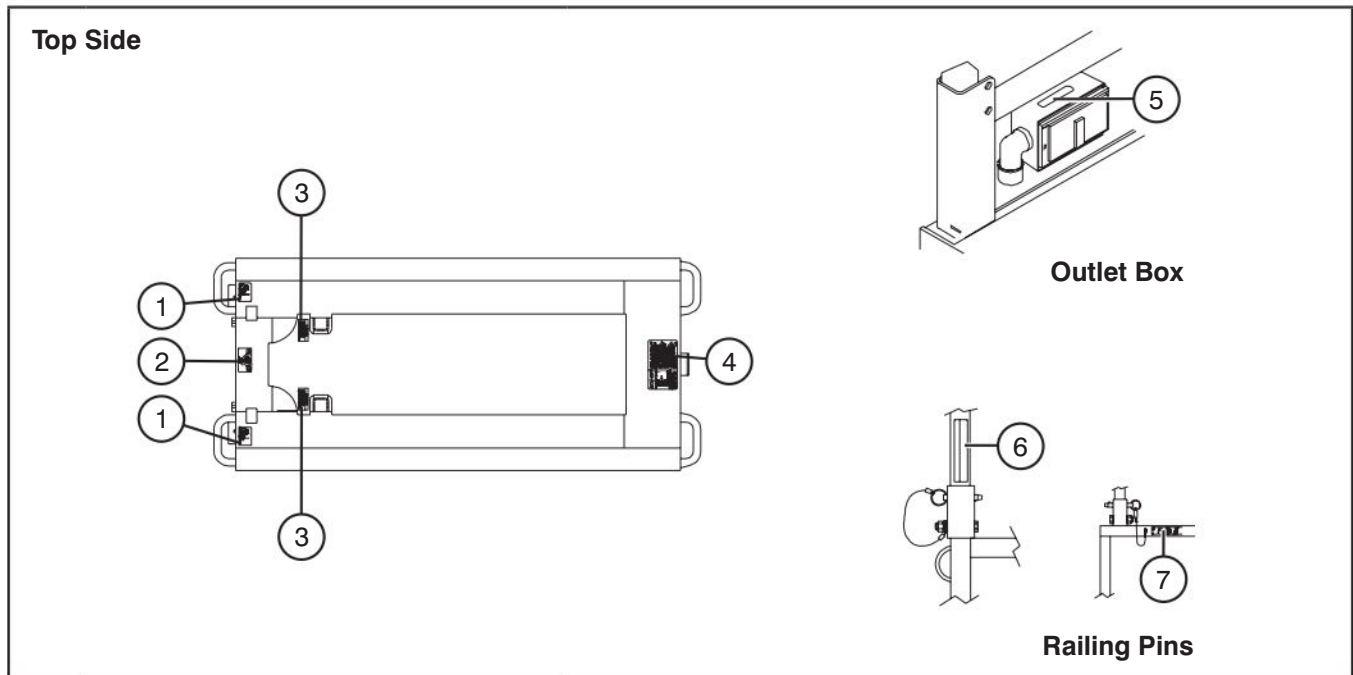

No.	Label Pictorial	Description
1		Forklift Pocket Insert fork fully into pocket to lift aerial platform.
2		Lift and Tie Down Points Only use these points for lifting or tying down.
3		Warning - Do Not Alter Aerial platform altering warning
4		Maintenance Support Instructions on use on maintenance support
5		Connect Platform AC Supply Connect AC power supply here for platform accessory outlet.
6		Falling Hazard - Railing Pins (Vertical) WARNING! Falling Hazard. Make sure hinged railing is pinned properly.
7		Falling Hazard - Railing Pins (Horizontal) WARNING! Falling Hazard. Make sure hinged railing is pinned.

Labels and Nameplates - Models 3215 & 3219

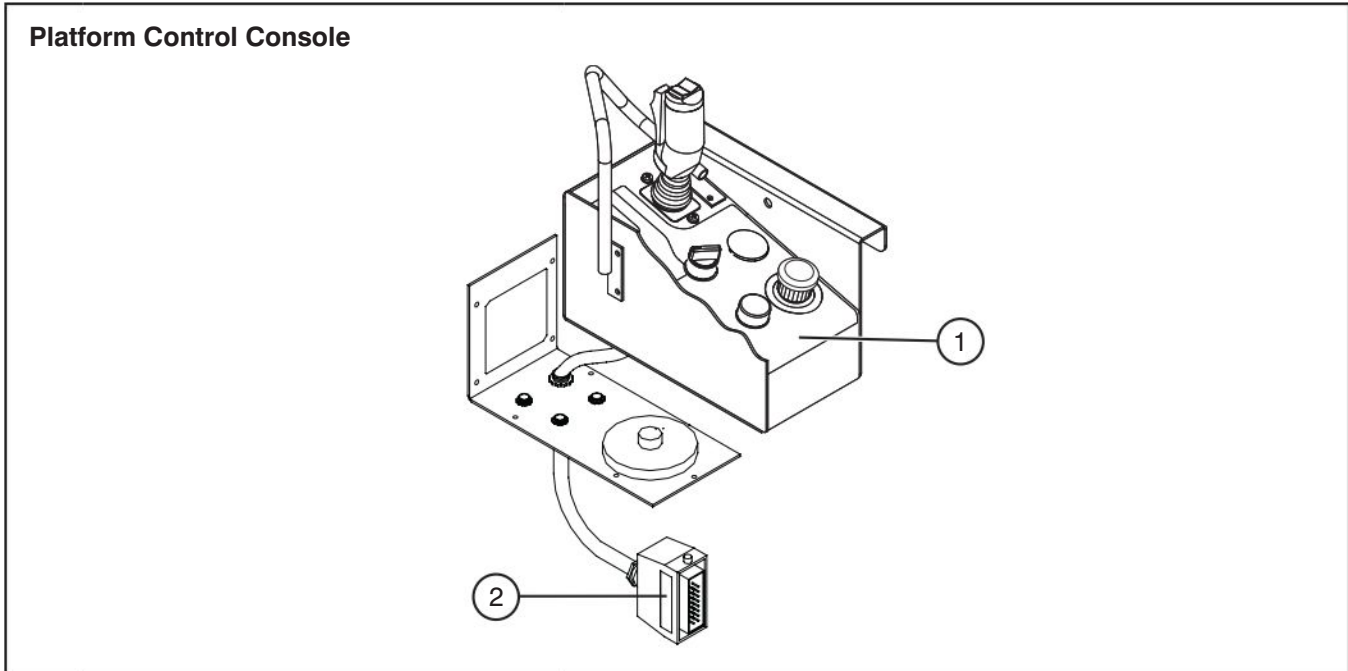

No.	Label Pictorial	Description
1		<p>Platform Control Console</p> <p>Squeeze “” trigger to enable controller.</p> <p>Operate “” rocker switch to steer.</p> <p>Move controller handle forward to “” raise or backward to “” lower platform.</p> <p>Move controller handle “” forward to drive forward or “” backward to drive reverse.</p> <p>Select “” lift, “” inclined drive (low speed/high torque) or “” level drive (high speed/low torque) mode.</p> <p>Select “” to sound horn.</p> <p>Push “” to disable controls. The operation light illuminates to indicate upper control availability and overload status. When light is “” flashing, it signals an overload function.</p>
2	<p>Hydraulic proportional 3215/19</p>	<p>Hydraulic Proportional</p> <p>Control box is suitable for use on hydraulic proportional aerial platforms.</p>

Labels and Nameplates - Models 3220, 3226, 46xx & 68xx

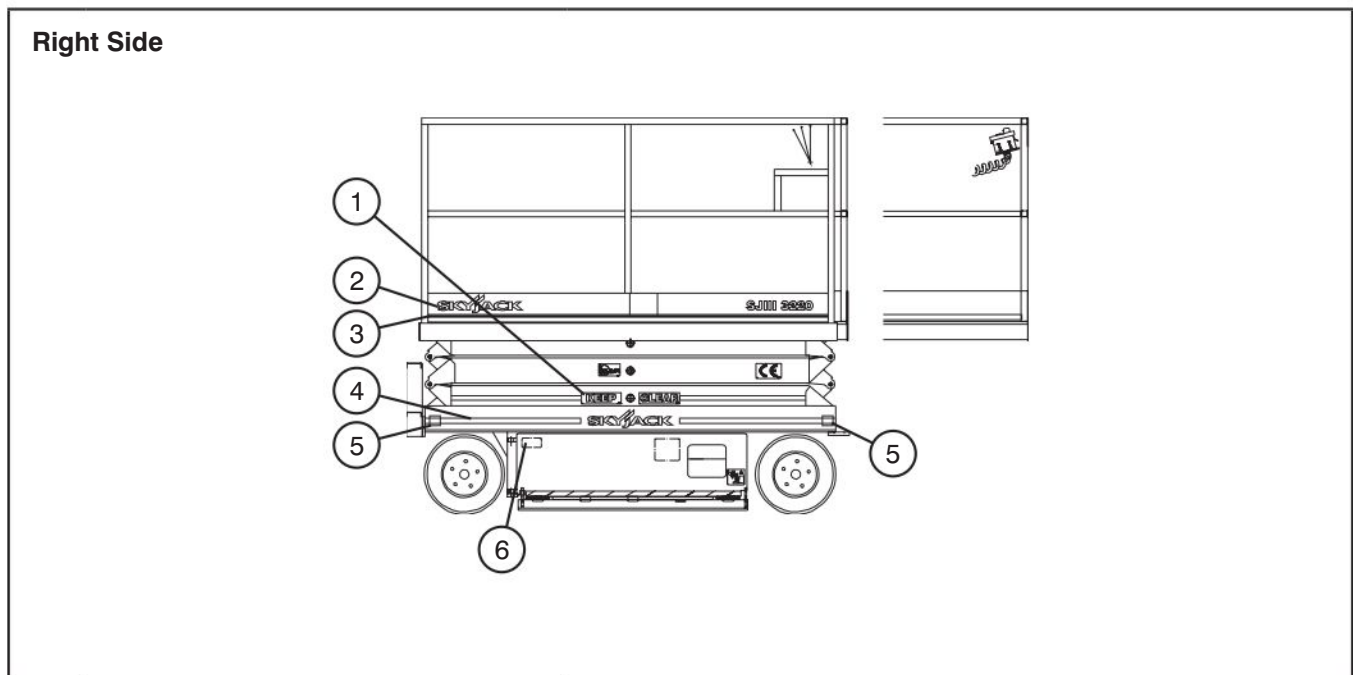

No.	Label Pictorial	Description
1		“Keep” Keep clear.
2		Skyjack Logo Small Skyjack logo - blue
3		Tape Blue/White Skyjack pinstripe
4		Tape - Red/Blue/Red Skyjack pinstripe
5		Wheel Load 820 kg/1800 lb.* Indicates rated wheel load. *Wheel load will vary with each model.
6		Fuse Fuse location

Labels and Nameplates - Models 3220, 3226, 46xx & 68xx

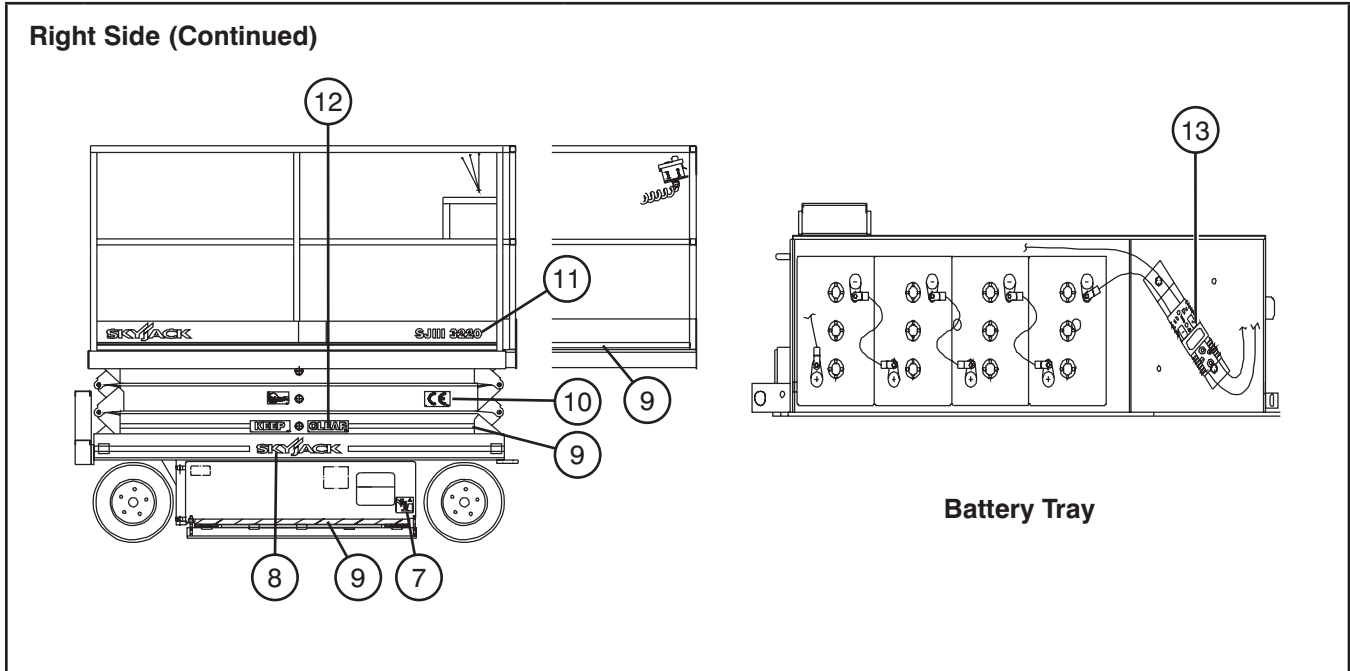

No.	Label Pictorial	Description
7		Crushing Hazard Danger - Crushing hazard
8		Skyjack Logo Small Skyjack logo - blue and red
9		Caution Tape Stripe Caution stripe
10		"CE" CE rating mark
11		Model Number* Product Identifier *Model number will vary, may not be as shown.
12		"Clear" Keep clear.
13		Battery - Charger Connection Connect charger to batteries at this point.



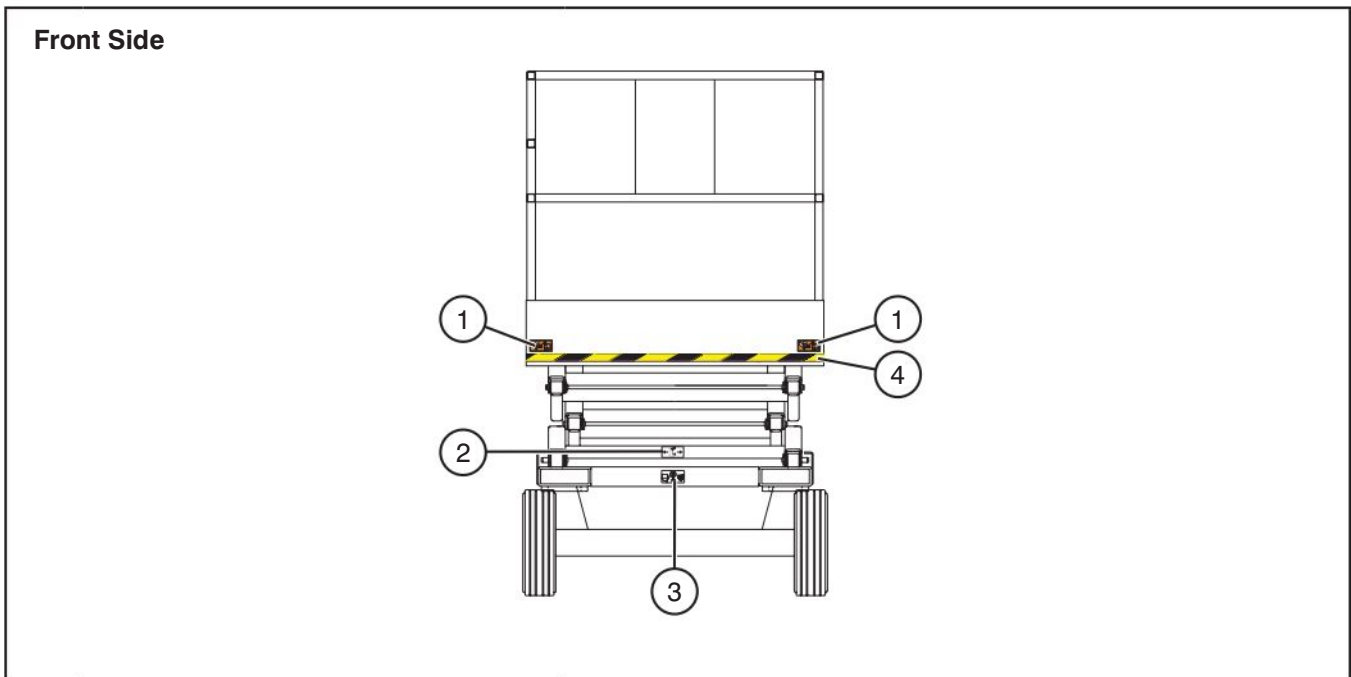

Labels and Nameplates - Models 3220, 3226, 46xx & 68xx

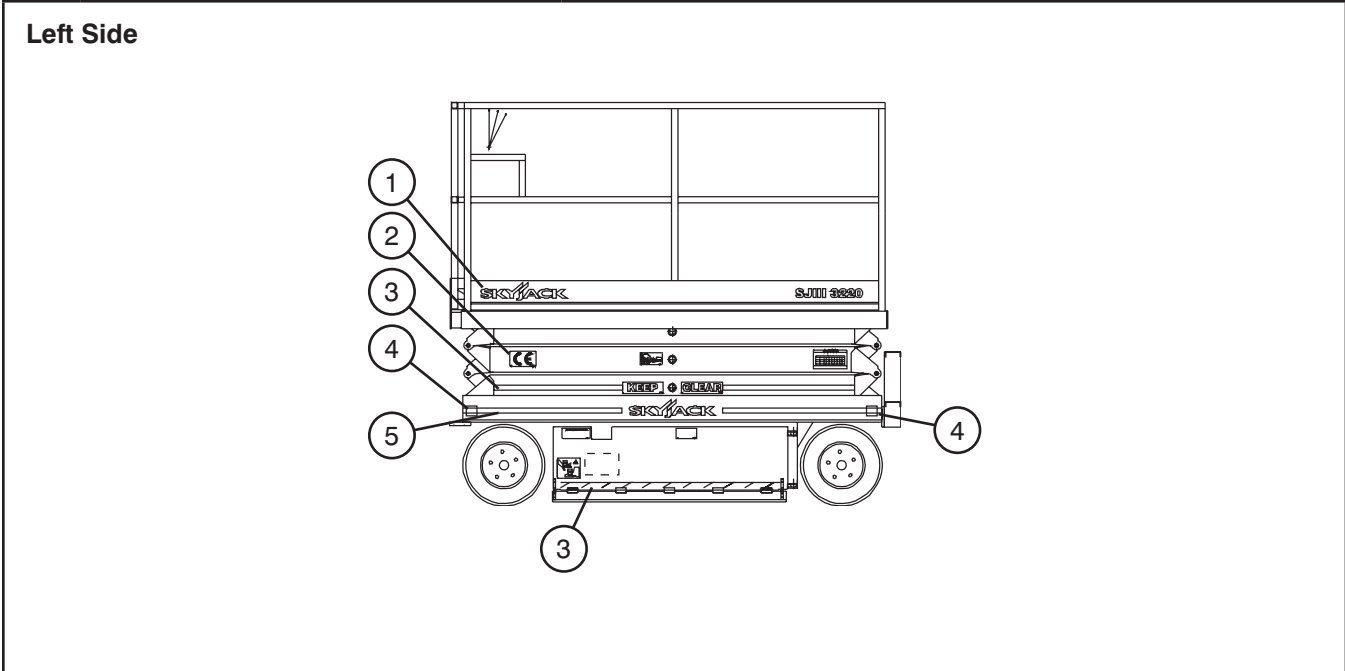

No.	Label Pictorial	Description
1		<p>Crushing Hazard Danger - Crushing hazard</p>
2		<p>Maintenance Support Deploy maintenance support here.</p>
3		<p>Lift and Tie Down Points Only use these points for lifting or tying down.</p>
4		<p>Caution Tape Stripe Caution stripe</p>

Labels and Nameplates - Models 3220, 3226, 46xx & 68xx

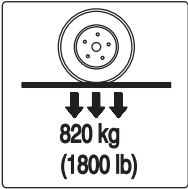

No.	Label Pictorial	Description
1		<p>Skyjack Logo</p> <p>Small Skyjack logo - blue</p>
2		<p>“CE”</p> <p>CE rating mark</p>
3		<p>Caution Tape Stripe</p> <p>Caution stripe</p>
4		<p>Wheel Load 820 kg/1800 lb.*</p> <p>Indicates rated wheel load. *Wheel load will vary with each model.</p>
5		<p>Tape - Red/Blue/Red</p> <p>Skyjack pinstripe</p>



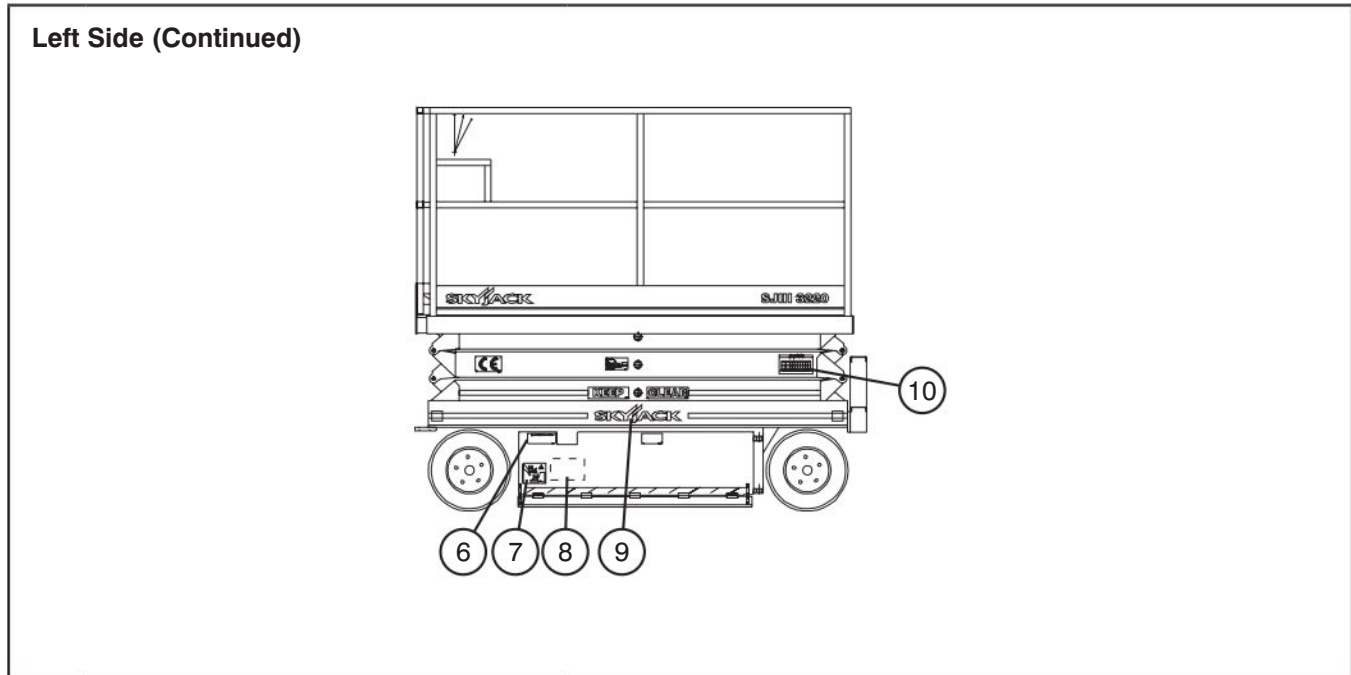



Labels and Nameplates - Models 3220, 3226, 46xx & 68xx

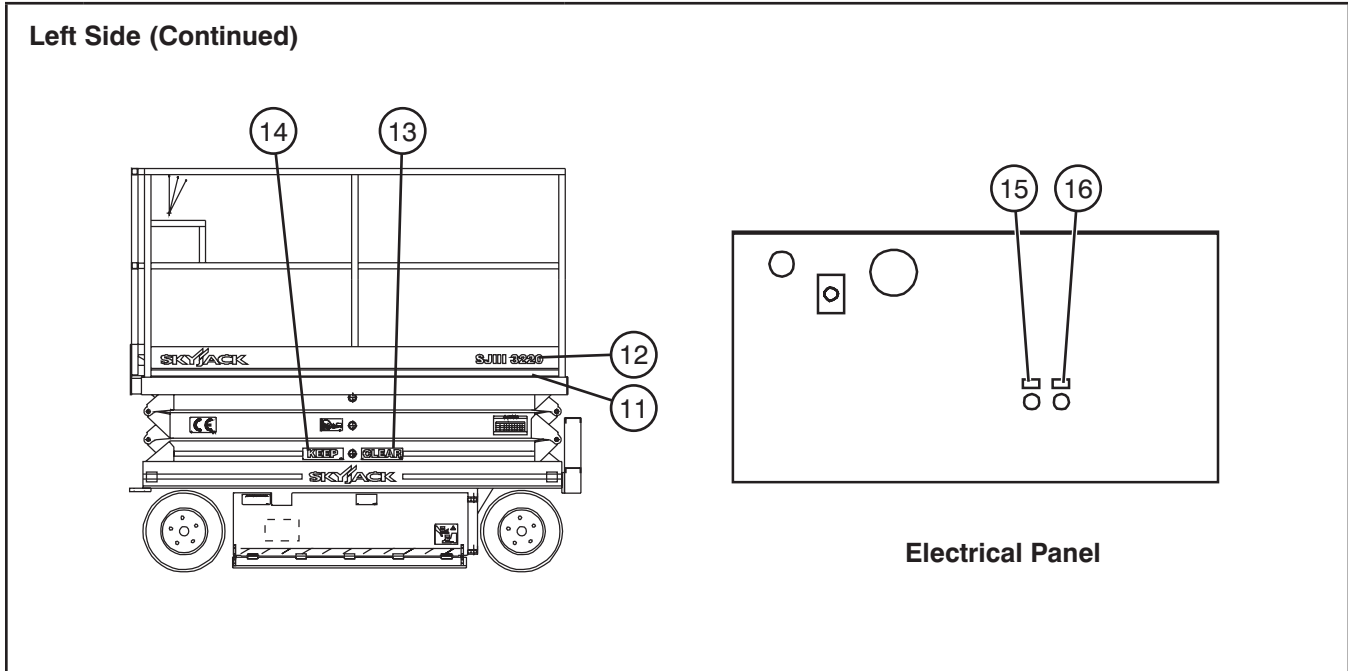





No.	Label Pictorial	Description
6		<p>Emergency Lowering Procedure</p> <p>In case of emergency, follow procedure outlined in label to lower the platform.</p>
7		<p>Crushing Hazard</p> <p>Danger - Crushing hazard</p>
8		<p>Hydraulic Oil ATF Dexron III</p> <p>Replace hydraulic fluid with ATF Dexron III only.</p>
9		<p>Skyjack Logo</p> <p>Small Skyjack logo - blue and red</p>
10		<p>Annual Inspection</p> <p>Ensure that work platform has received annual inspection prior to operation.</p>

Labels and Nameplates - Models 3220, 3226, 46xx & 68xx

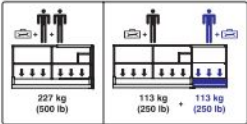

No.	Label Pictorial	Description
11		Tape Blue/White Skyjack pinstripe
12		Model Number* Product Identifier *Model number will vary, may not be as shown.
13		“Clear” Keep clear.
14		“Keep” Keep clear.
15		Ground Circuit Breaker Push to reset ground circuit breaker.
16		Power Circuit Breaker Push to reset power circuit breaker.

Labels and Nameplates - Models 3220, 3226, 46xx & 68xx

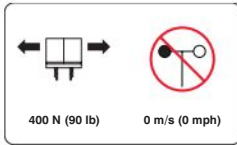
No.	Label Pictorial	Description
1		<p>Warning - Do Not Alter</p> <p>Aerial platform altering warning</p>
2		<p>Winching/Towing/Pushing Procedure</p> <p>Winching/towing/pushing procedure. Ensure brake is released and free-wheeling valve is open before moving the unit manually.</p>
3		<p>Platform Capacity*</p> <p>Rated work load in each configuration *Platform capacity varies over different units.</p>
4		<p>Lanyard Anchorage Point</p> <p>Attach anchorage harness lanyard here.</p>
5		<p>Falling Hazard - Railing Pins (Vertical)</p> <p>WARNING! Falling Hazard. Make sure hinged railing is pinned properly.</p>
6		<p>Horizontal Load Rating*</p> <p>Apply no more than the indicated side load. Operate below indicated wind speed only. *Horizontal load rating will vary, may not be as shown.</p>

Labels and Nameplates - Models 3220, 3226, 46xx & 68xx

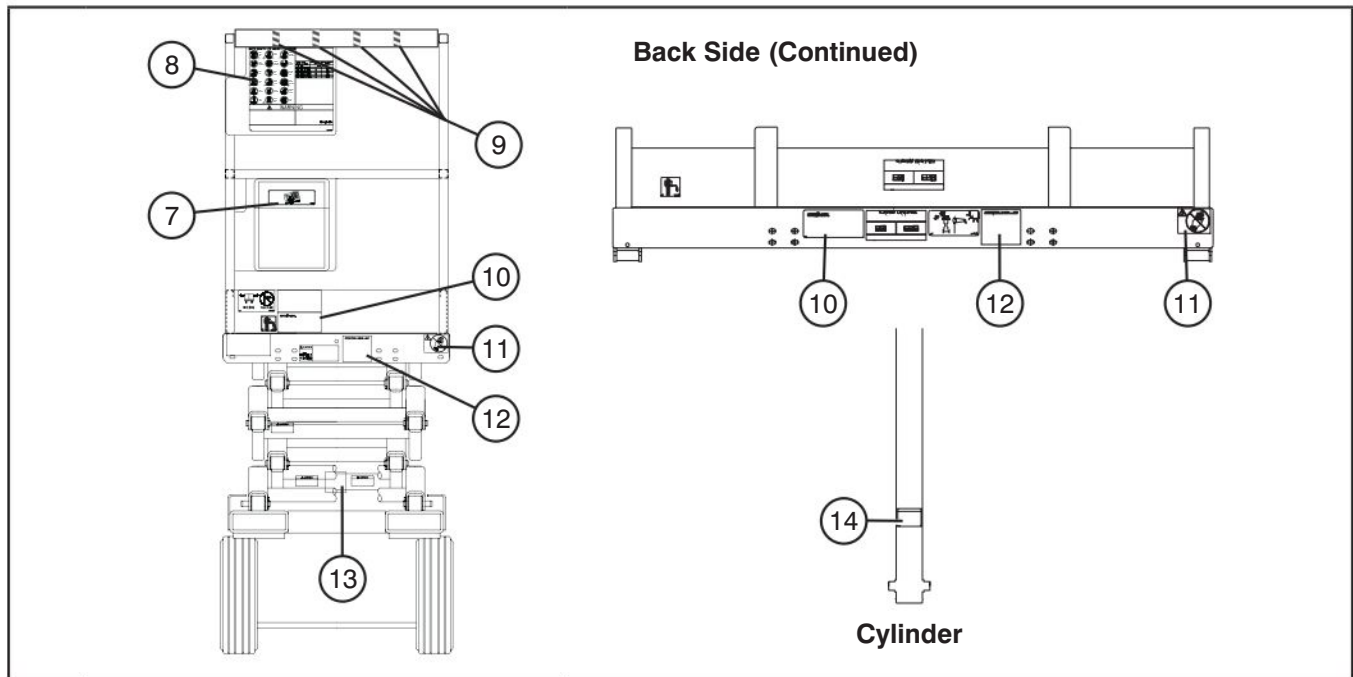

No.	Label Pictorial	Description
7		Manual Storage Box Indicates location of operating manual.
8		Hazard Identification Read and understand the outlined risks associated with this work platform prior to operation.
9		Caution Tape Stripe Caution stripe
10		Standards Compliance Indicates standards to which the work platform complies.
11		No Jewelry Caution - Do not wear jewelry.
12		Operator Checklist Operator checklist. Perform check prior to use.
13		Emergency Lowering Procedure In case of emergency, follow procedure outlined in label to lower the platform.
14		Orifice Installed Orifice installation warning

Labels and Nameplates - Models 3220, 3226, 46xx & 68xx

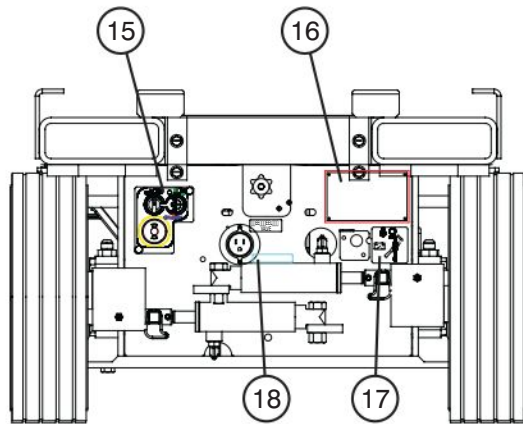

Back (32xx)

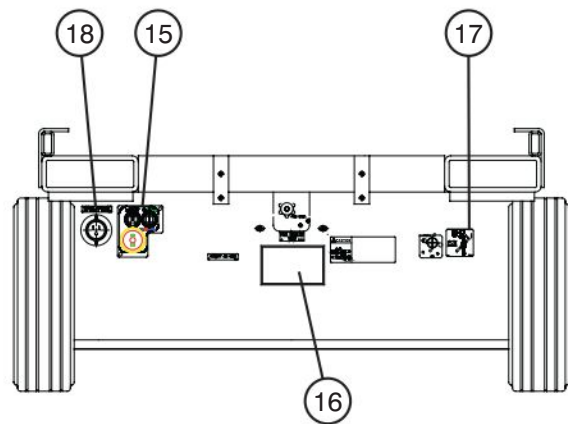



Back (46xx & 68xx)

No.	Label Pictorial	Description
15		<p>Base Control Console</p> <p>Select “↓” to lower or “↑” raise platform.</p> <p>Select “” platform to enable platform controls, “” off to disable controls or “” base to enable base control console.</p> <p>Push “” to disable controls.</p>
16		<p>Serial Plate*</p> <p>Product identification and specifications *Serial plates will vary, may not be as shown.</p>
17		<p>Main Power Disconnect</p> <p>Rotate clockwise to turn on main power, rotate counterclockwise to turn off main power, insert padlock to lock in position.</p>
18		<p>Connect Platform AC Supply</p> <p>Connect AC power supply here for platform accessory outlet.</p>

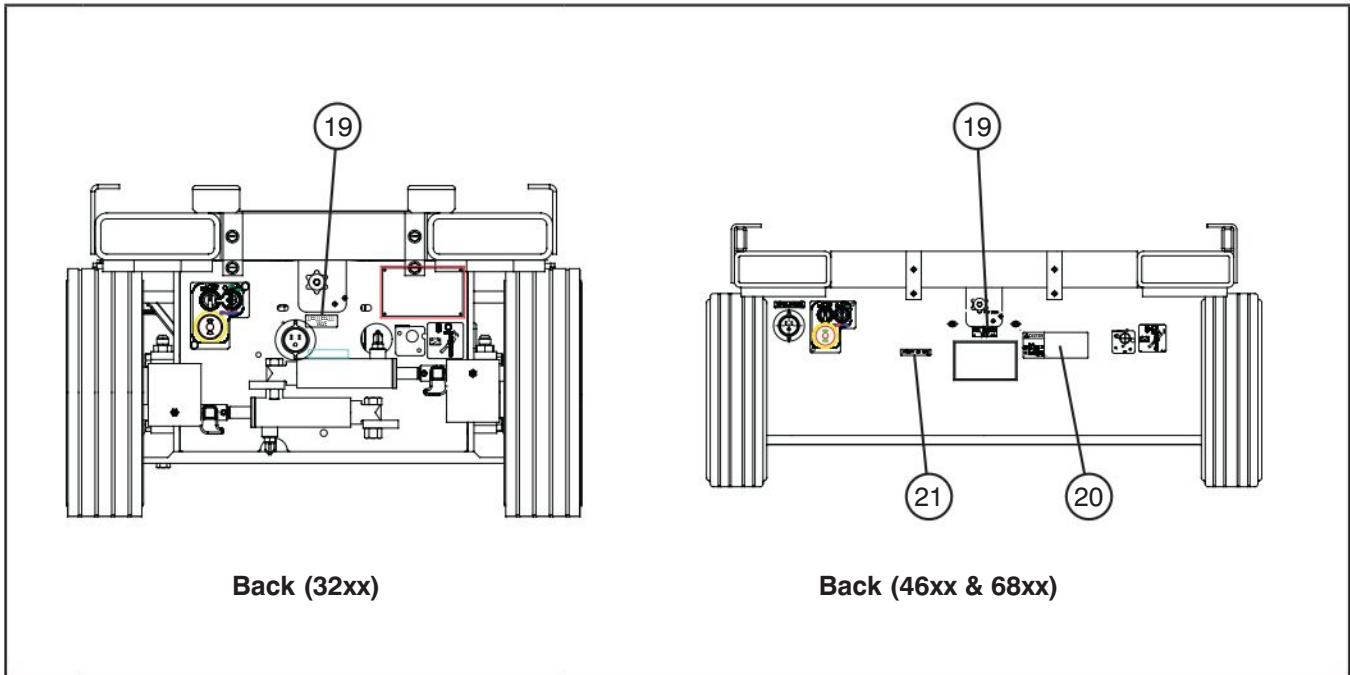
Labels and Nameplates - Models 3220, 3226, 46xx & 68xx

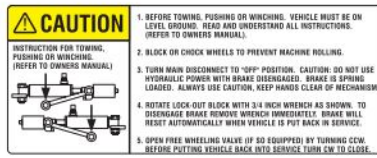

No.	Label Pictorial	Description
19		<p>Free-wheeling Valve</p> <p>Open valve to initiate free wheeling prior to winching/towing/pushing.</p>
20		<p>Winching/Towing/Pushing Procedure</p> <p>Winching/towing/pushing procedure. Ensure brake is released and free-wheeling valve is open before moving the unit manually.</p>
21		<p>Connect Air Supply</p> <p>Connect platform air supply here.</p>

Labels and Nameplates - Models 3220, 3226, 46xx & 68xx

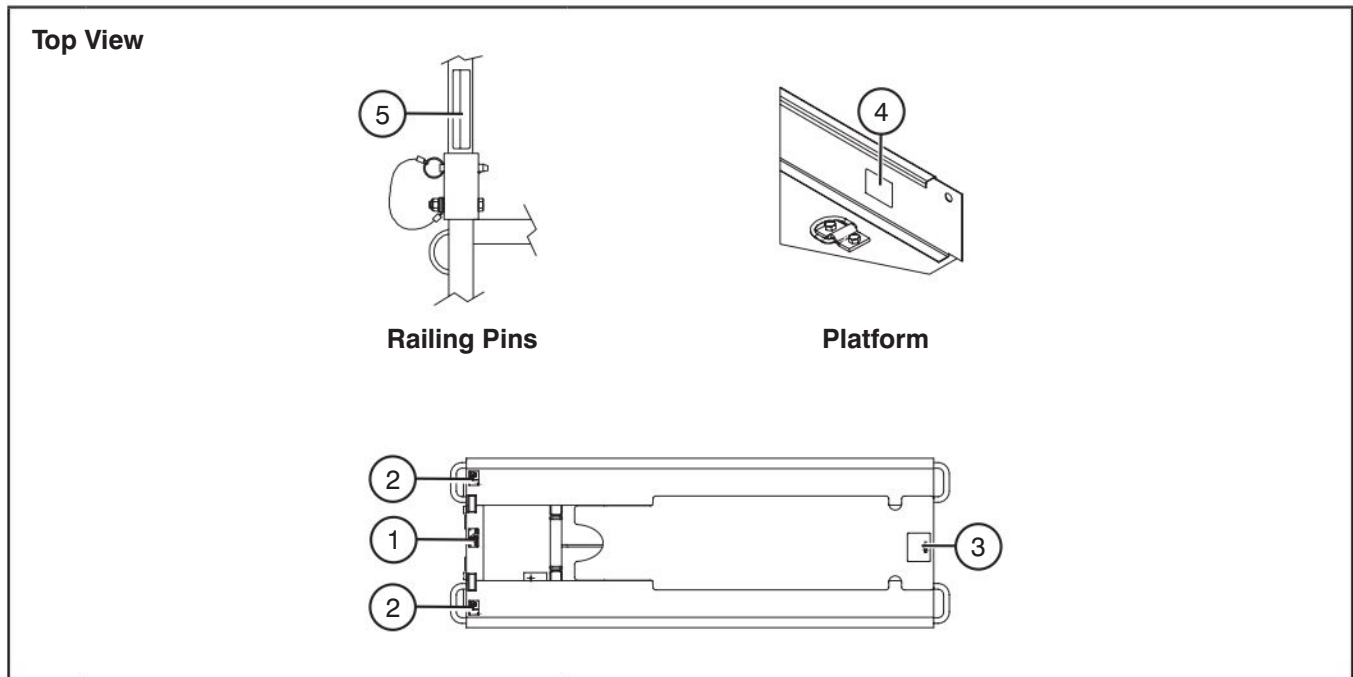

No.	Label Pictorial	Description
1		Lift and Tie Down Points Only use these points for lifting or tying down.
2		Forklift Pocket Insert fork fully into pocket to lift aerial platform.
3		Maintenance Support Instructions on use on maintenance support
4		Lanyard Anchorage Point Attach anchorage harness lanyard here.
5		Falling Hazard - Railing Pins (Vertical) WARNING! Falling Hazard. Make sure hinged railing is pinned properly.

Labels and Nameplates - Models 3220, 3226, 46xx & 68xx

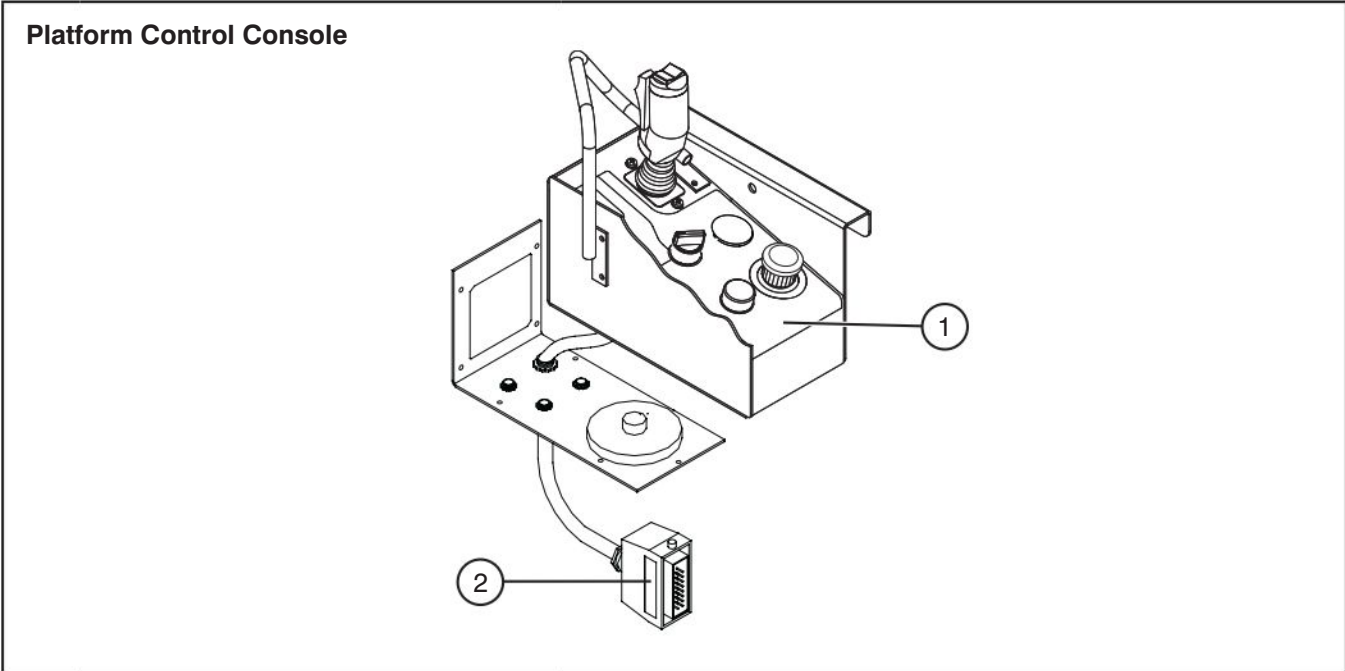

No.	Label Pictorial	Description
1		<p>Platform Control Console</p> <p>Squeeze “” trigger to enable controller.</p> <p>Operate “” rocker switch to steer.</p> <p>Move controller handle forward to “” raise or backward to “” lower platform.</p> <p>Move controller handle “” forward to drive forward or “” backward to drive reverse.</p> <p>Select “” lift, “” inclined drive (low speed/high torque) or “” level drive (high speed/low torque) mode.</p> <p>Select “” to sound horn.</p> <p>Push “” to disable controls. The operation light illuminates to indicate upper control availability and overload status. When light is “” flashing, it signals an overload function.</p>
2		<p>Hydraulic Proportional</p> <p>Control box is suitable for use on hydraulic proportional aerial platforms.</p>

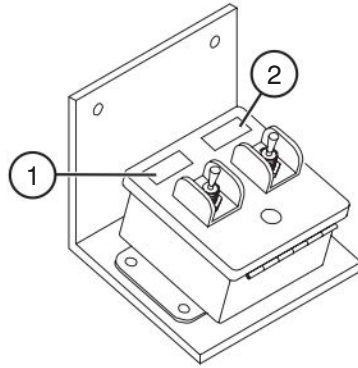

Labels and Nameplates - Models 3220, 3226, 46xx & 68xx

Control Box - Powered Extension Platform

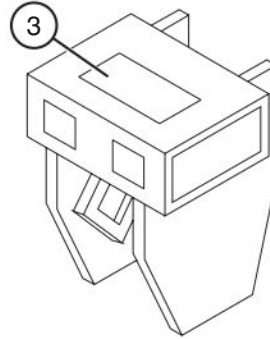

Cross Member- 1st Level Inside Scissors



No.	Label Pictorial	Description
1		<p>Lift Enable</p> <p>Select to enable lift mode.</p>
2		<p>Powered Extension Platform Extend/Retract</p> <p>Select “” to extend or “” retract powered extension platform.</p>
3		<p>Emergency Lowering Procedure</p> <p>In case of emergency, follow procedure outlined in label to lower the platform.</p>



Reliable lift solutions by people who care.

www.skyjack.com